

ELLINGTON | DUTCO

ONE
RIVER POINT

PROJECT BRIEF

A HIGH-END URBAN ESCAPE THAT CAPTURES THE MOOD AND RHYTHM OF BUSINESS BAY



ONE RIVER POINT

ELLINGTON | DUTCO

One River Point is an architectural masterpiece that stands tall and proud, overlooking the mesmerizing Dubai Canal and the iconic Burj Khalifa. Its design seamlessly blends elegance, innovation, and a connection to the urban environment.

One River Point presents an array of world-class amenities that cater to the wellness-oriented and sophisticated lifestyle of its residents. The amenities are celebrated as an exclusive zone combining various spaces through a striking formal expression that adds a touch of architectural distinction and visual appeal.

Ellington Properties and Dutco are bringing together a wealth of experience and expertise in the development of One River Point.

Combining Ellington's resident-first philosophy with the attention to detail and efficiency for which Dutco is renowned, we can achieve perfection with speed. Our partnership marks a new era of growth for Ellington, and the rapid expansion of Dubai.



City Walk

Burj Khalifa

Dubai International
Financial Centre

Sheikh Zayed Road

Business Bay
Metro Station

Dubai Opera

Dubai Fountain

The Dubai Mall

Dubai Water Footbridge

ONE
RIVER POINT

Dubai Water
Canal Boardwalk

Dubai Water Canal

Al Asayel St.

Dubai Water Canal

Al Aamal St.

DRIVING DISTANCES



DUBAI WATER CANAL BOARDWALK	1 minute
DUBAI WATERFALL	2 minutes
BUSINESS BAY METRO STATION BUSINESS BAY MARINA AL QUOZ POND PARK	5 minutes
BURJ KHALIFA AND DUBAI MALL	7 minutes
MUSEUM OF THE FUTURE	8 minutes
DUBAI INTERNATIONAL FINANCIAL CENTRE CITY WALK MEYDAN RACECOURSE	10 minutes
MALL OF THE EMIRATES	13 minutes
DUBAI DESIGN DISTRICT DUBAI FESTIVAL CITY KITE BEACH	15 minutes
BURJ AL ARAB	17 minutes
PALM JUMEIRAH	19 minutes
EMIRATES GOLF CLUB DUBAI INTERNATIONAL AIRPORT	20 minutes
AL MAKTOUM INTERNATIONAL AIRPORT	39 minutes



ACTUAL AERIAL
VIEW

DESIGN STRATEGY

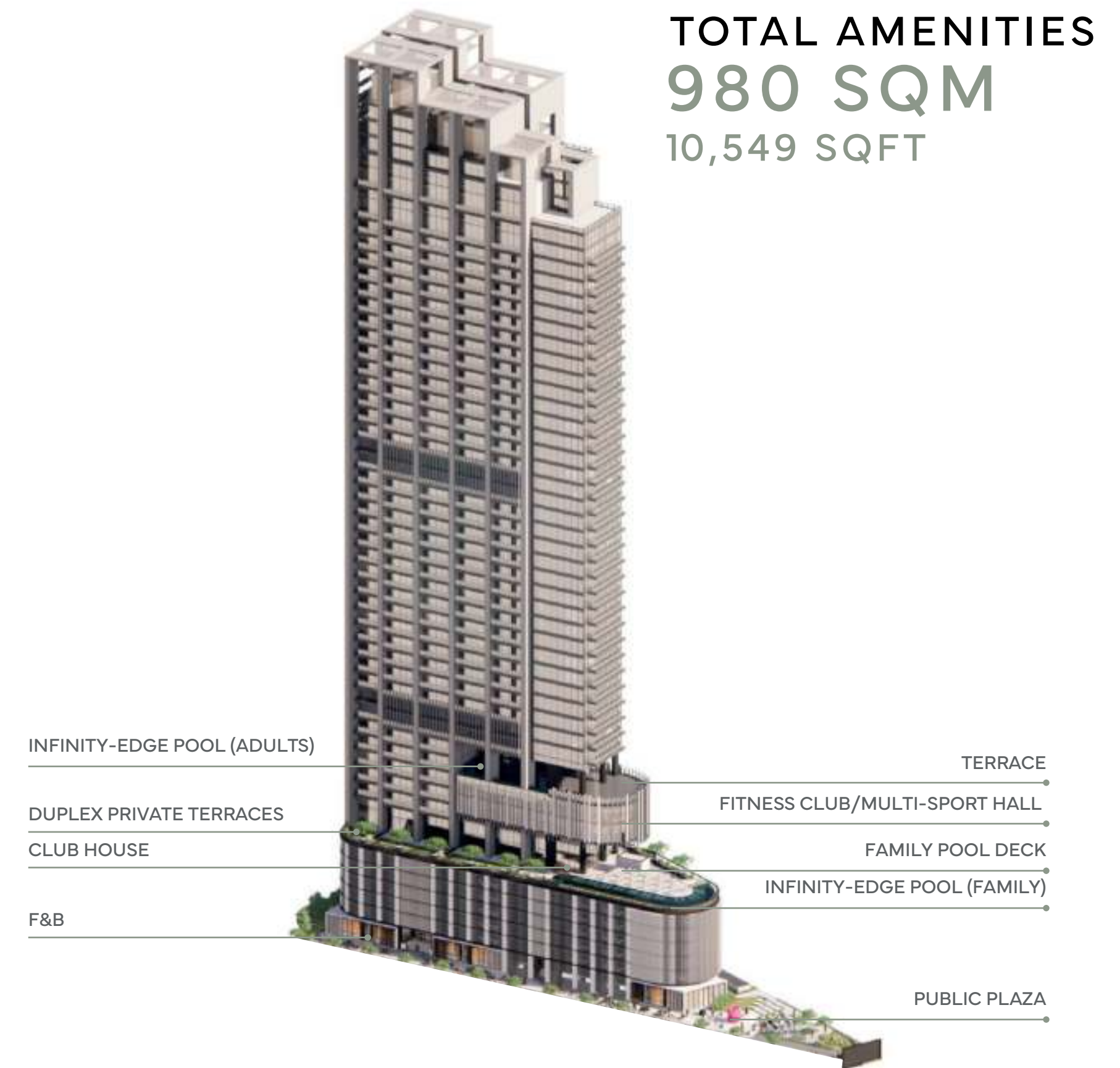
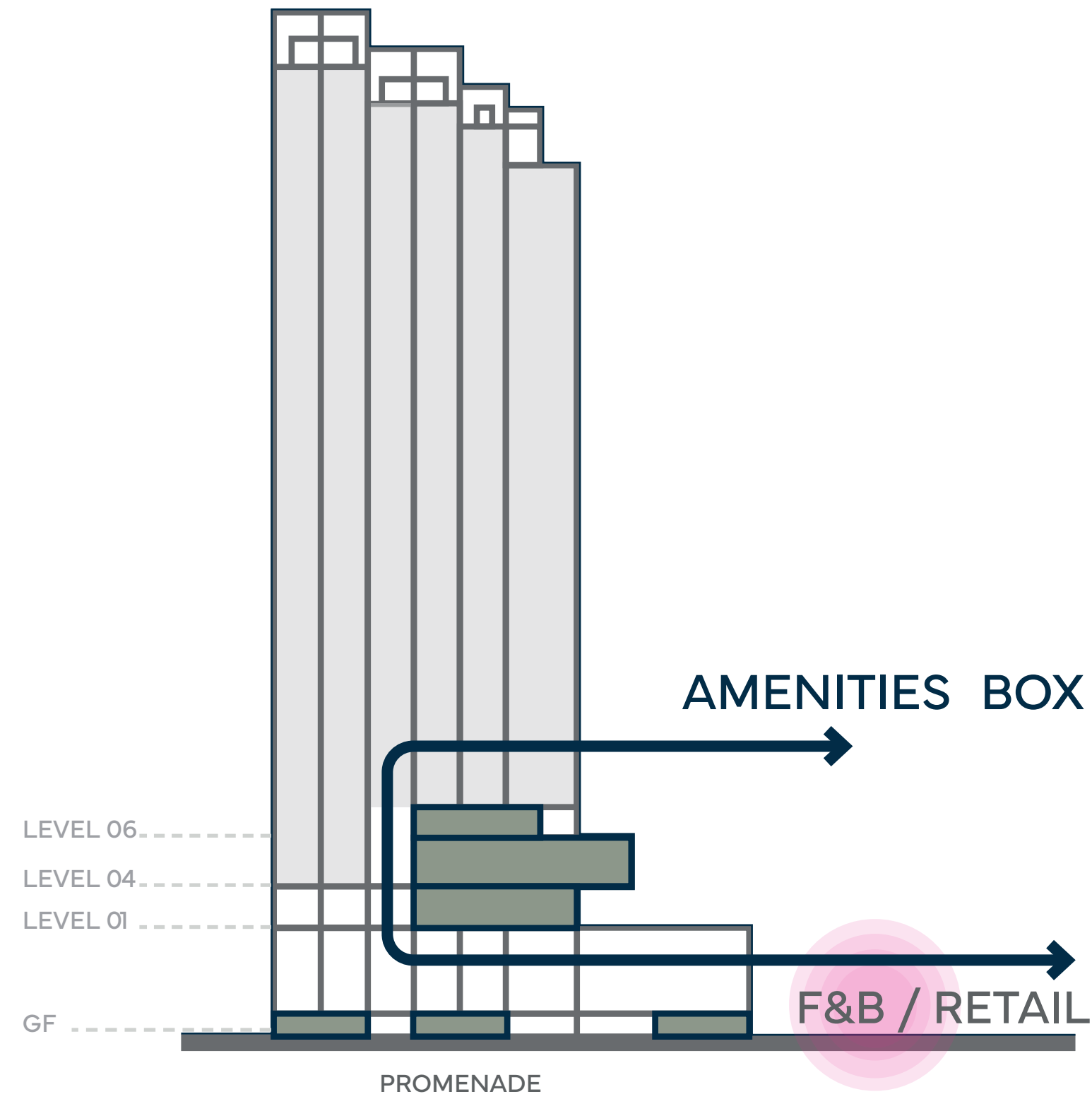
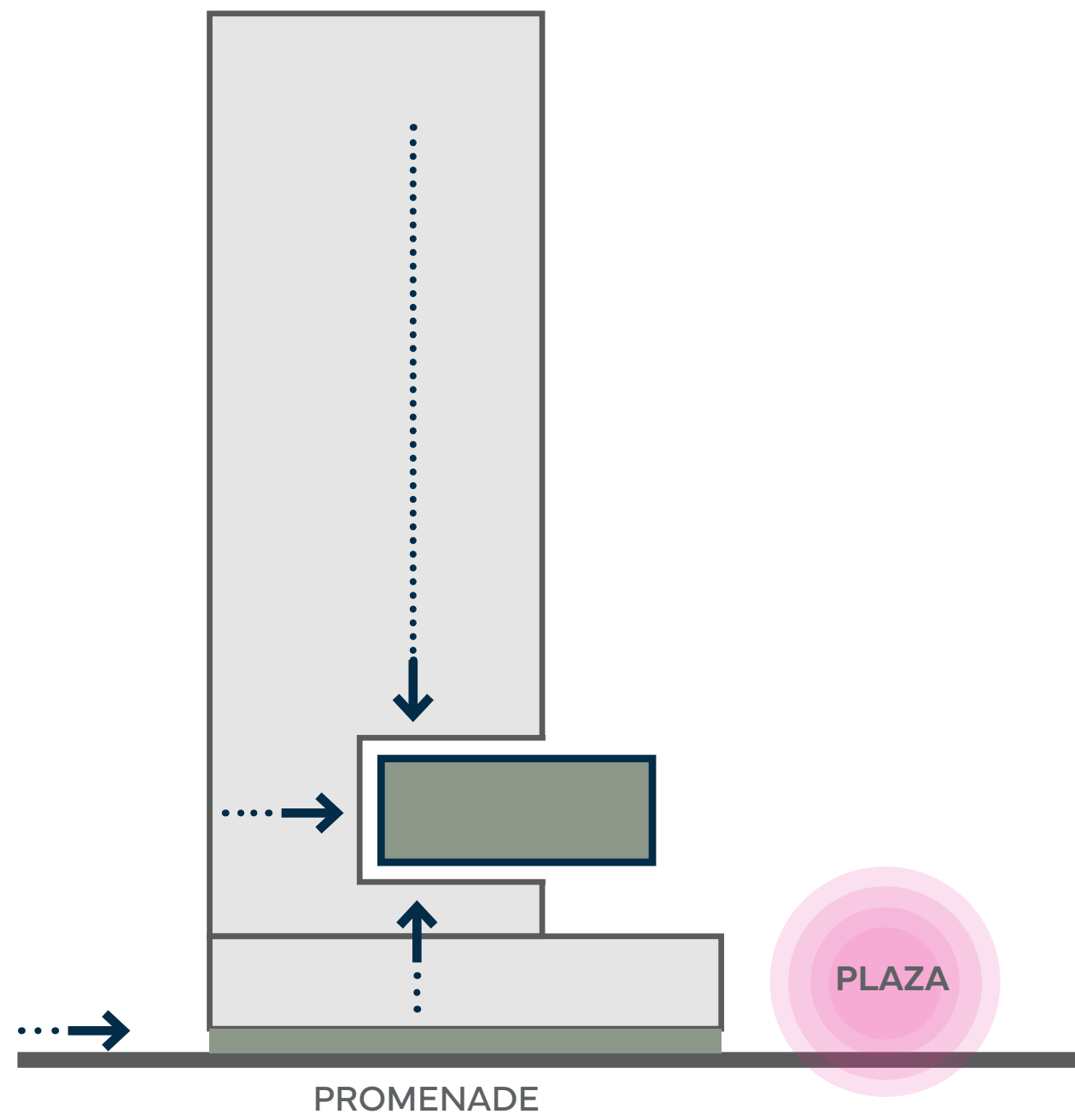

Exclusive amenities are combined in one zone and celebrated in a protruding structural expression. While featured public and F&b spaces are located at the ground floor.

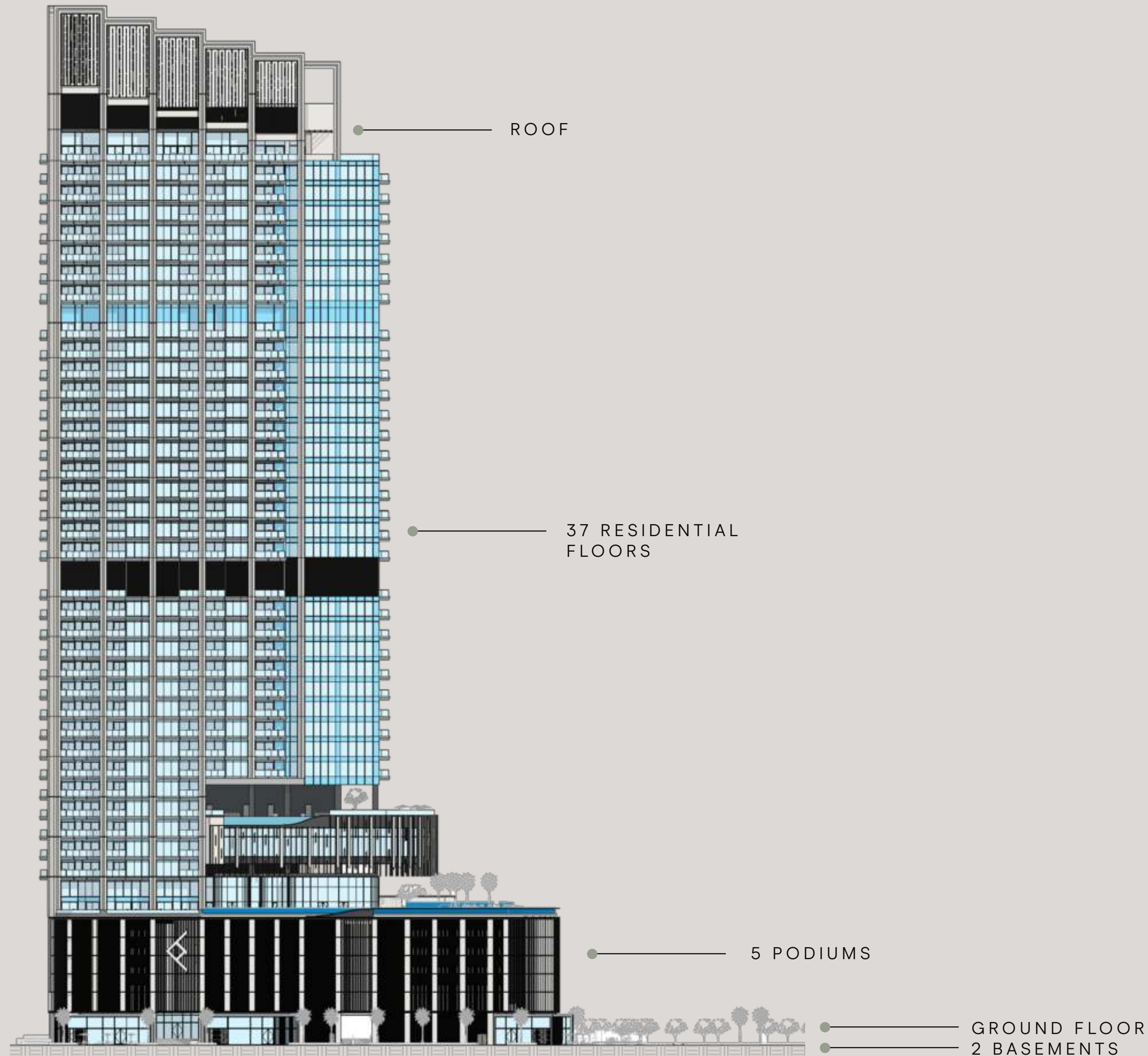

BUILDING CONFIGURATION

ELEVATORS	7 passenger elevators 1 service elevator
------------------	---

ANTICIPATED SERVICE CHARGE	AED 20 per sq.ft
-----------------------------------	------------------

ANTICIPATED COMPLETION DATE	Q2 2027
------------------------------------	---------

PARKING	Studio, 1 and 2-bedroom: 1 car parking space 3 and 4-bedroom: 2 car parking spaces
----------------	---

OWNERSHIP	Freehold
------------------	----------

SIZE RANGE PER UNIT TYPE

STUDIO	From 487 sq. ft
1 BEDROOM	From 958 sq. ft to 1,199 sq. ft
2 BEDROOM	From 1,447 sq. ft to 1,795 sq. ft
3 BEDROOM	From 2,397 sq. ft to 3,968 sq. ft
4 BEDROOM DUPLEX	From 4,971 sq. ft to 5,576 sq. ft
3 BEDROOM PENTHOUSE	From 3,502 sq. ft to 3,734 sq. ft
4 BEDROOM PENTHOUSE	From 5,847 sq. ft

NUMBER OF UNITS PER TYPE

STUDIO	19 units
1 BEDROOM	94 units
2 BEDROOM	146 units
3 BEDROOM	31 units
4 BEDROOM DUPLEX	2 units
3 BEDROOM PENTHOUSE	2 units
4 BEDROOM PENTHOUSE	1 unit



**GROUND FLOOR
AMENITIES**



ARRIVAL
AREA



**CONCIERGE
SERVICE**



LOBBY
RECEPTION



LOBBY
AREA



LIFT
LOBBY



DUBAI WATER CANAL
BOARDWALK

[CLICK HERE TO VIEW
THE 360 EXPERIENCE](#)



DUBAI WATER CANAL

DUBAI WATER CANAL BOARDWALK

GROUND FLOOR AMENITIES PLAN

- ① VEHICLE ENTRANCE & EXIT
- ② DROP-OFF AREA
- ③ LOBBY ENTRANCE
- ④ LOBBY LOUNGE
- ⑤ LOBBY RECEPTION
- ⑥ LIFT LOBBY
- ⑦ ACCESS TO BOARDWALK
- ⑧ OUTDOOR SEATING AREAS



**FIRST FLOOR
AMENITIES**



POOL
DECK

CLICK HERE TO VIEW
THE 360° EXPERIENCE



ELEGANT ENERGETIC

CLUBHOUSE

The Clubhouse sits on the upper floor of The Podium, overlooking the swimming pool through large glass doors.





**KIDS
PLAY**



IMMERSIVE
ROOM



1ST FLOOR AMENITIES PLAN

- | | |
|--------------------------|---|
| 1 BEACH CLUB POOL | 11 FEMALE CHANGE ROOM |
| 2 KIDS POOL | 12 MALE CHANGE ROOM |
| 3 POOL SUN LOUNGERS AREA | 13 BATHROOM FOR PEOPLE OF DETERMINATION |
| 4 CABANAS | 14 LIFT LOBBY |
| 5 OUTDOOR SEATING AREA | |
| 6 KIDS PLAY AREA | |
| 7 CLUB LOUNGE | |
| 8 CO-WORKING AREA | |
| 9 KITCHENETTE | |
| 10 IMMERSIVE ROOM | |

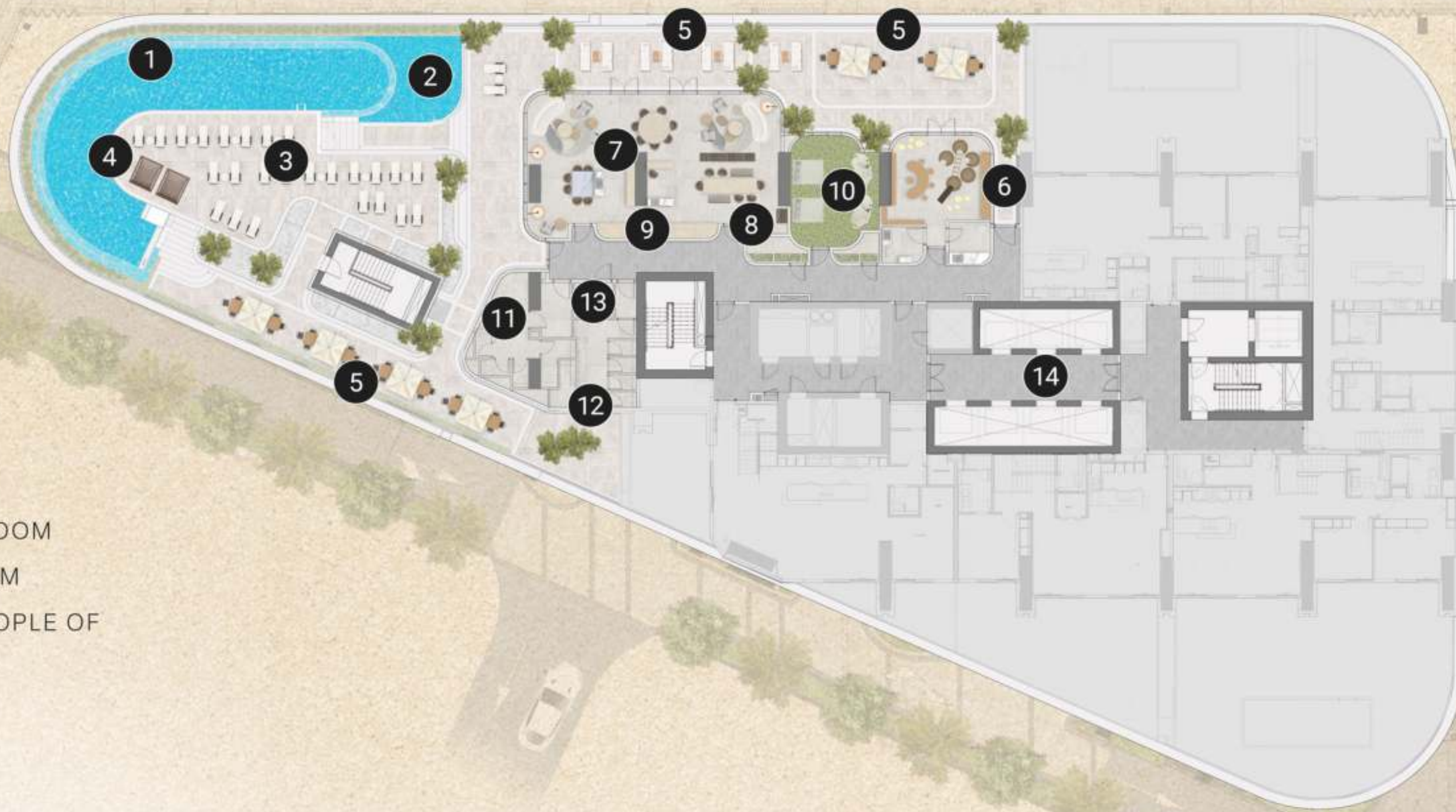

**FOURTH & SIXTH FLOOR
AMENITIES**



FITNESS
STUDIO

CLICK HERE TO VIEW
THE 360° EXPERIENCE

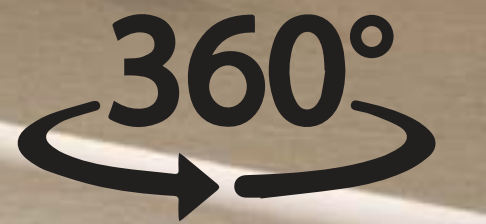

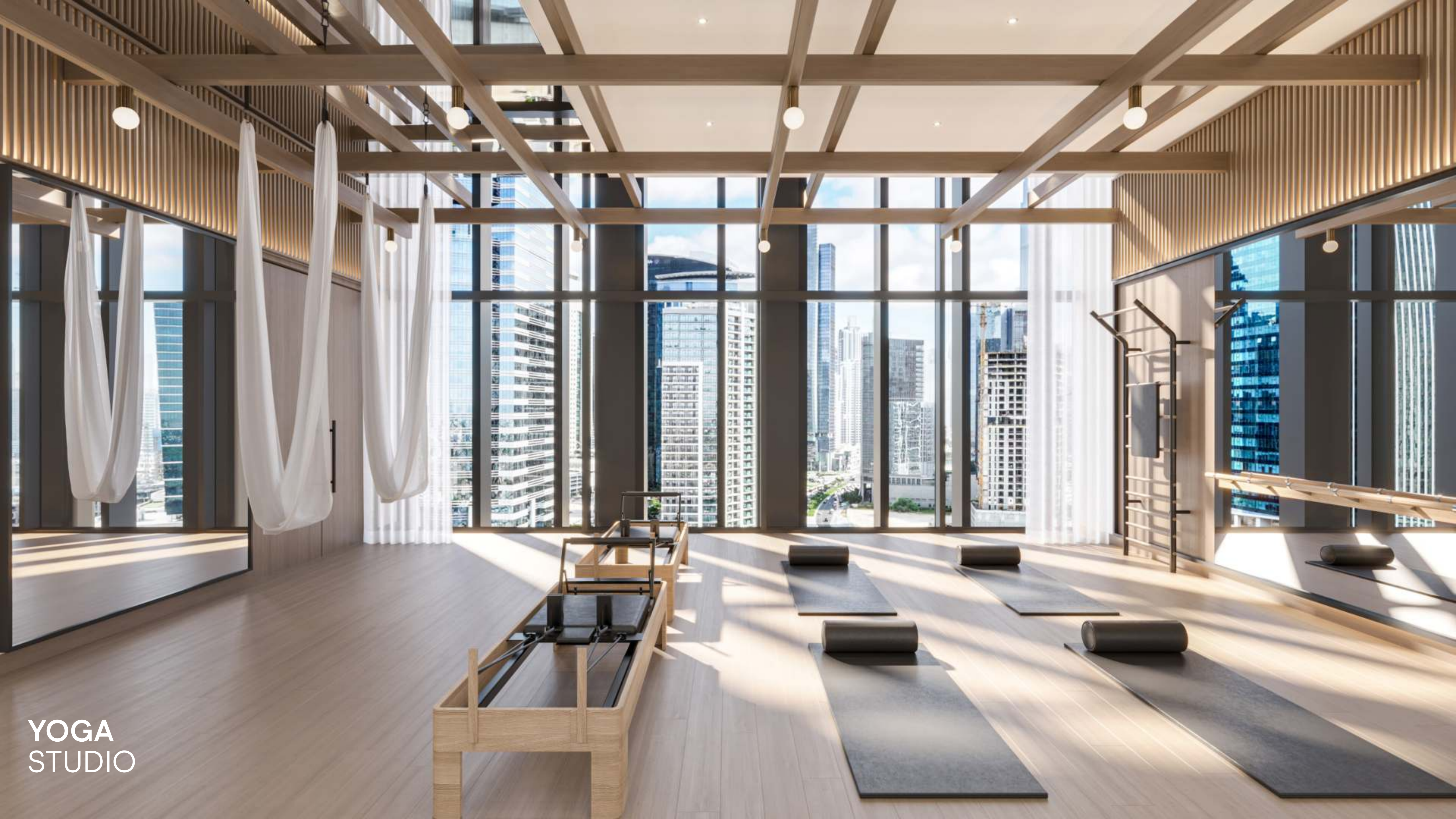

YOGA
STUDIO



4TH FLOOR AMENITIES PLAN

- ① FITNESS GYM
- ② CLIMBING NET
- ③ YOGA STUDIO
- ④ REFRESHMENT STATION
- ⑤ MALE CHANGING ROOM
- ⑥ FEMALE CHANGING ROOM
- ⑦ BATHROOM FOR PEOPLE OF DETERMINATION
- ⑧ LIFT LOBBY





6TH FLOOR AMENITIES PLAN

- ① ADULT POOL AREA
- ② POOL SUN LOUNGERS
- ③ CABANAS
- ④ OUTDOOR SEATING AREA
- ⑤ CHANGING ROOMS
- ⑥ LIFT LOBBY



APARTMENTS





COOL, CALM CONTENT

LIVING & DINING

High-end detailing with a contemporary edge retains the effortlessness of the building's striking facade.

ADDITIONAL KITCHEN FEATURES



Integrated kitchen drop-in sink with vegetable and glass rinser



Integrated pop-up Downdraft Hood Slider with touch control and charcoal filter

* The additional kitchen feature is exclusively available for 3-bedroom apartments, duplexes, and penthouses.



**TYPICAL
KITCHEN**

FRESH & FUNCTIONAL

TYPICAL BATHROOM

Warm finishes and intricately applied detailing set the scene for self-care and relaxing cleansing rituals.



HOME
AUTOMATION





As well as being the project developer, Dutco's top-tier contracting division will be the main contractors for the construction and delivery of the development. With over 70 years of presence in the UAE, Dutco is renowned for high quality and on-time delivery.

Dutco has been involved in many iconic projects, including the world's largest mall, Dubai Mall, Museum of the Future and Dubai International Airport, in addition to many residential and commercial projects.

**CONSTRUCTION
CONTRACTOR**

FLOOR PLANS



TYPICAL FLOOR PLANS



1ST FLOOR TYPICAL PLAN

 3 BEDROOM DUPLEX
LOWER LEVEL

 4 BEDROOM DUPLEX
LOWER LEVEL



4-BR
DUPLEX
TYPE A
01

3-BR
DUPLEX
TYPE C
02

3-BR
DUPLEX
TYPE A
05

3-BR
DUPLEX
TYPE B
04

4-BR
DUPLEX
TYPE B
03



2ND FLOOR TYPICAL PLAN

 3 BEDROOM DUPLEX
UPPER LEVEL

 4 BEDROOM DUPLEX
UPPER LEVEL



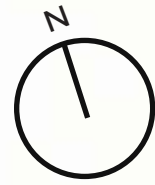

3RD FLOOR TYPICAL PLAN

-  1 BEDROOM
-  2 BEDROOM



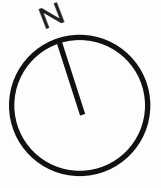

4TH FLOOR
TYPICAL PLAN



1 BEDROOM



2 BEDROOM



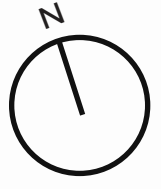

5TH FLOOR
TYPICAL PLAN



1 BEDROOM



2 BEDROOM



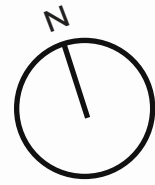

6TH FLOOR TYPICAL PLAN

 1 BEDROOM

 2 BEDROOM



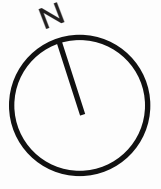

7TH FLOOR TYPICAL PLAN



1 BEDROOM



2 BEDROOM



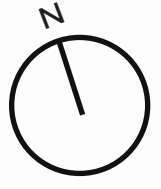

8TH - 16TH FLOOR
TYPICAL PLAN



1 BEDROOM



2 BEDROOM



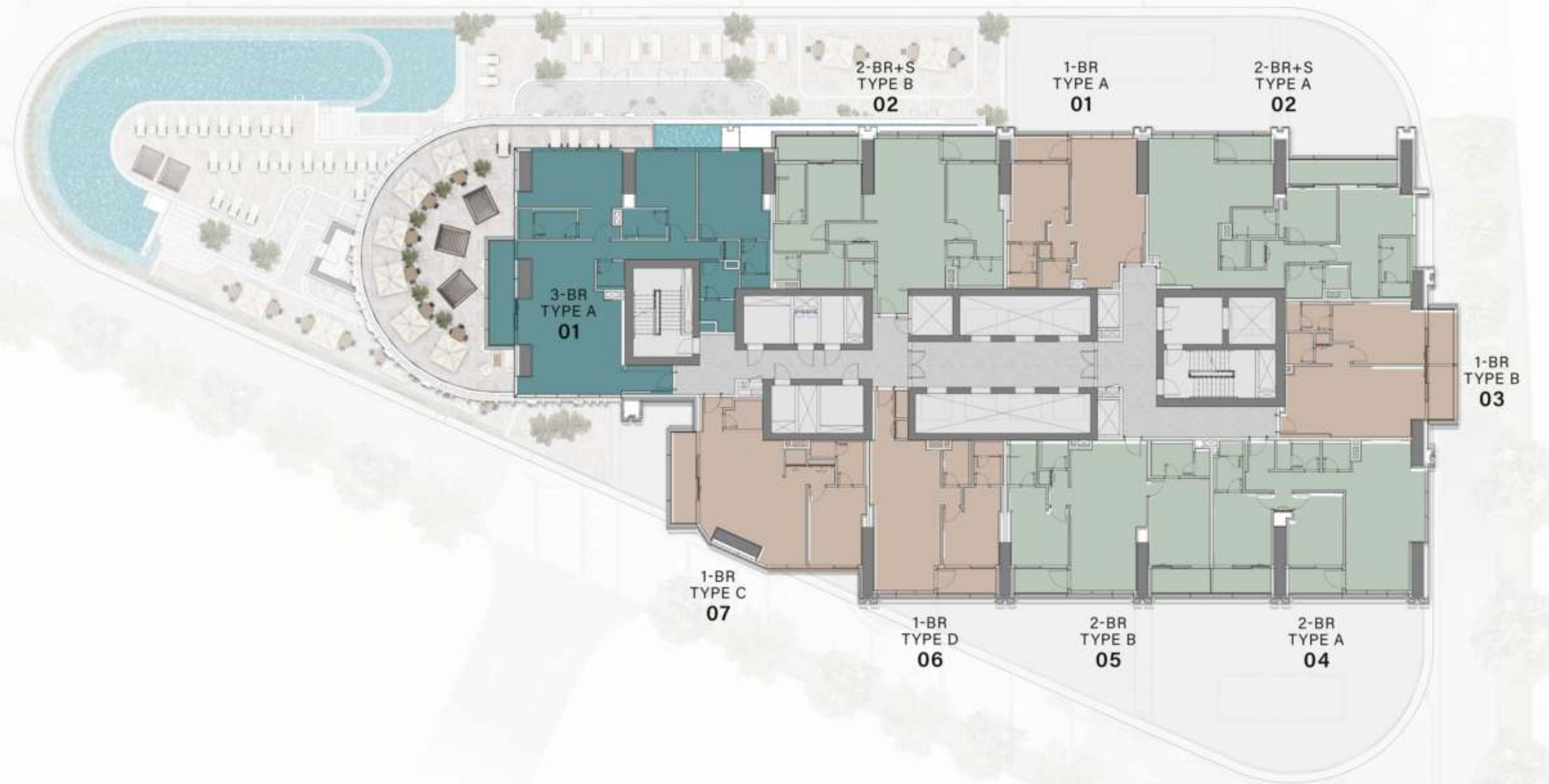

3 BEDROOM

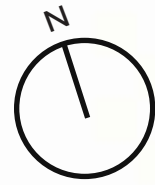



18TH - 36TH FLOOR TYPICAL PLAN

-  STUDIO
-  1 BEDROOM
-  2 BEDROOM
-  3 BEDROOM



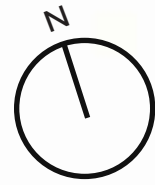

37TH FLOOR TYPICAL PLAN

 3 BEDROOM
PENTHOUSE

 4 BEDROOM
PENTHOUSE

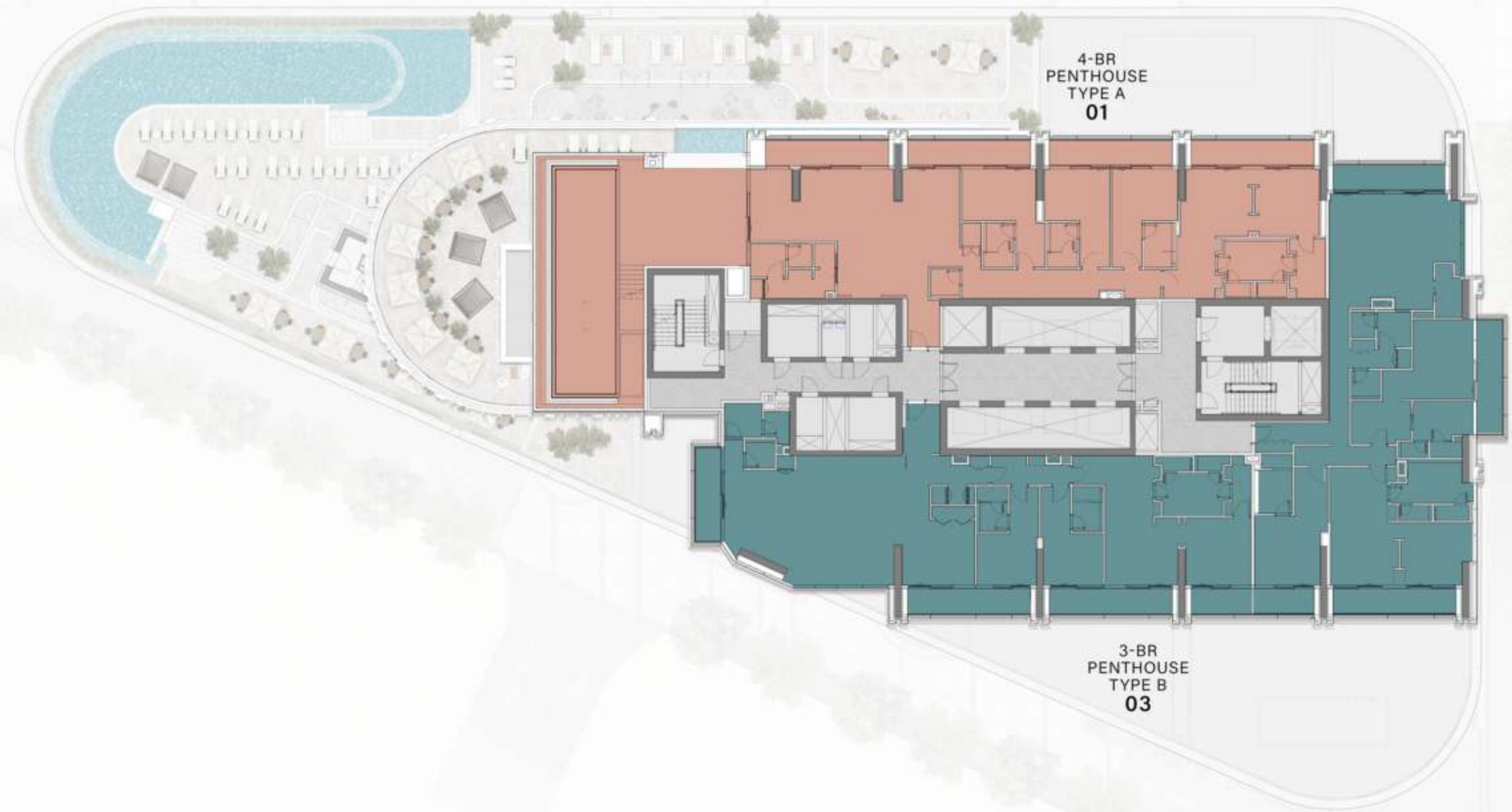

4-BR
PENTHOUSE
TYPE A
01

3-BR
PENTHOUSE
TYPE C
02

3-BR
PENTHOUSE
TYPE B
03

APARTMENT PLANS

STUDIO

TYPE A

Internal Living Area : **401.06 Sq. Ft**
Outdoor Living Area : **86.43 Sq. Ft**
Total Living Area : **487.50 Sq. Ft**

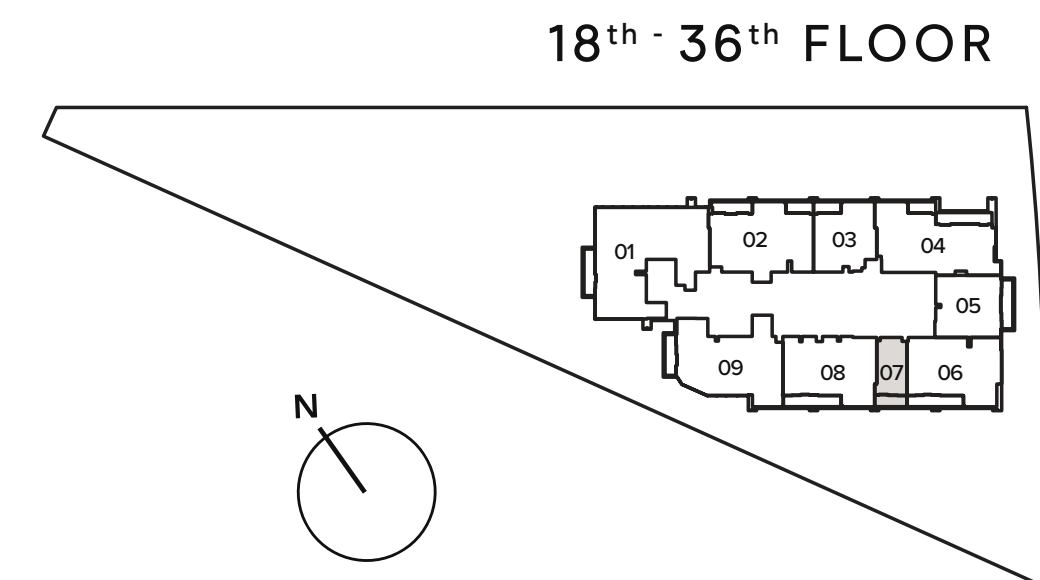
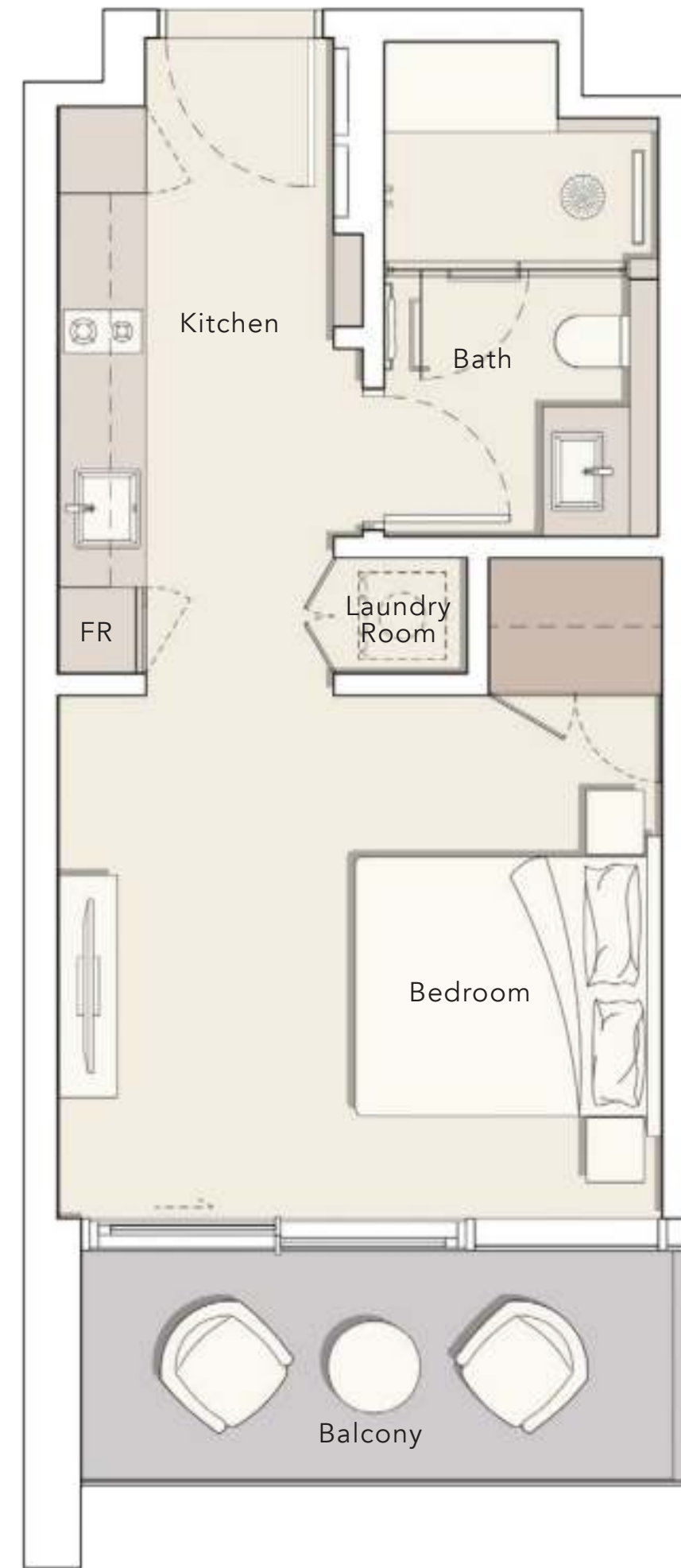

1 BEDROOM

TYPE A

Internal Living Area : 886.41 Sq. Ft

Outdoor Living Area : 71.69 Sq. Ft

Total Living Area : 958.10 Sq. Ft



3rd FLOOR

301

4th FLOOR

401

5th FLOOR

501

6th FLOOR

601

7th FLOOR

701

8th - 16th FLOOR

803

18th - 36th FLOOR

1803

8th - 16th FLOOR

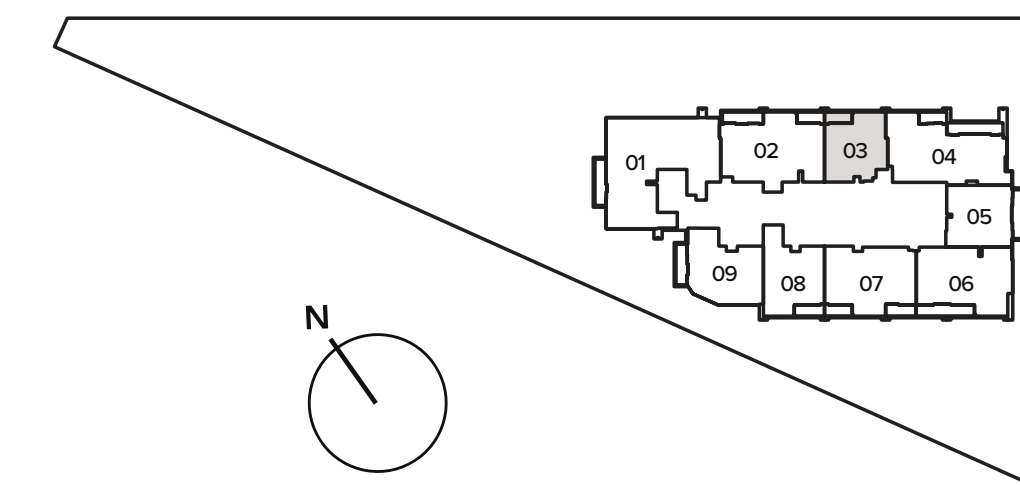

1 BEDROOM

TYPE B

Internal Living Area : 930.43 Sq. Ft

Outdoor Living Area : 129.81 Sq. Ft

Total Living Area : 1060.25 Sq. Ft



3rd FLOOR

303

7th FLOOR

703

4th FLOOR

403

8th - 16th FLOOR

805

5th FLOOR

503

18th - 36th FLOOR

1805

6th FLOOR

603

8th - 16th FLOOR

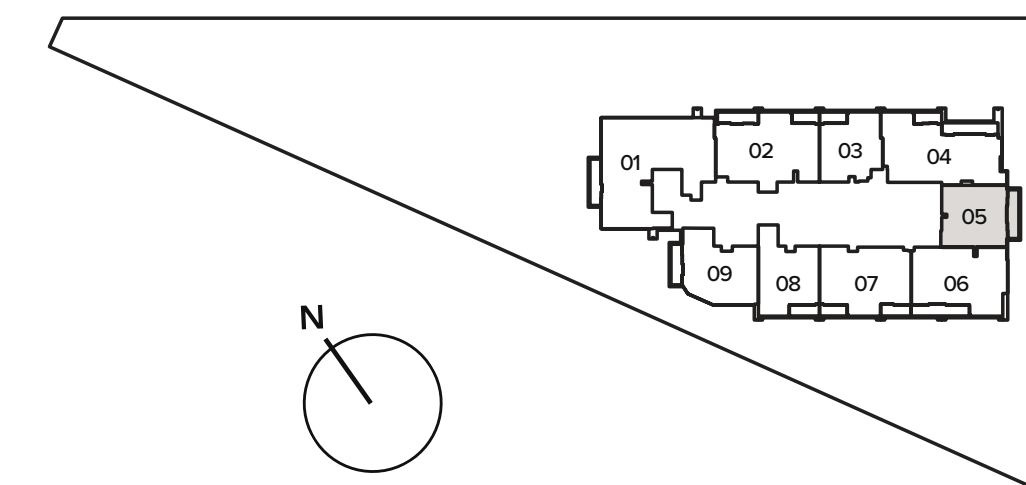

1 BEDROOM

TYPE C

Internal Living Area : 1090.49 Sq. Ft

Outdoor Living Area : 107.10 Sq. Ft

Total Living Area : 1197.59 Sq. Ft



3rd FLOOR

307

7th FLOOR

707

4th FLOOR

407

8th - 16th FLOOR

809

5th FLOOR

507

6th FLOOR

607

8th - 16th FLOOR

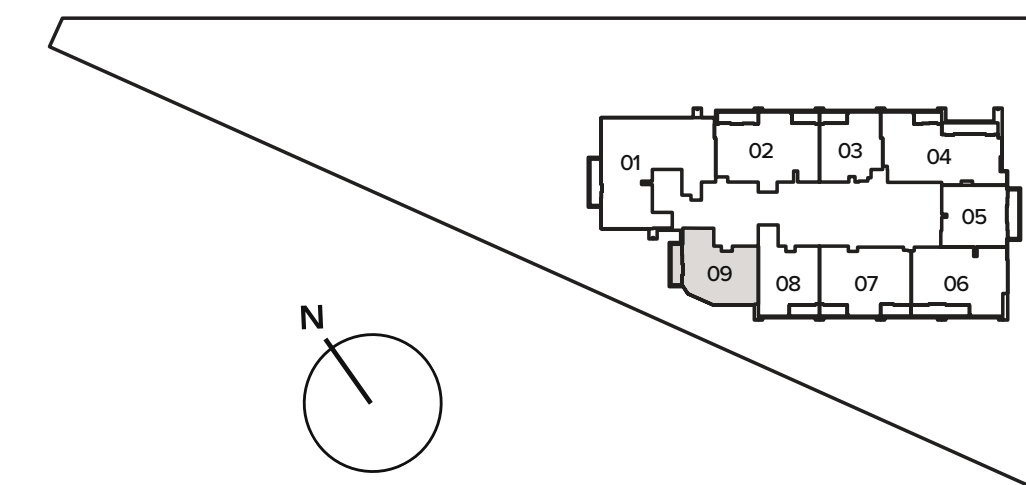

1 BEDROOM

TYPE D

Internal Living Area : 991.03 Sq. Ft

Outdoor Living Area : 77.82 Sq. Ft

Total Living Area : 1068.86 Sq. Ft



3rd FLOOR

306

7th FLOOR

706

4th FLOOR

406

8th - 16th FLOOR

808

5th FLOOR

506

6th FLOOR

606

8th - 16th FLOOR

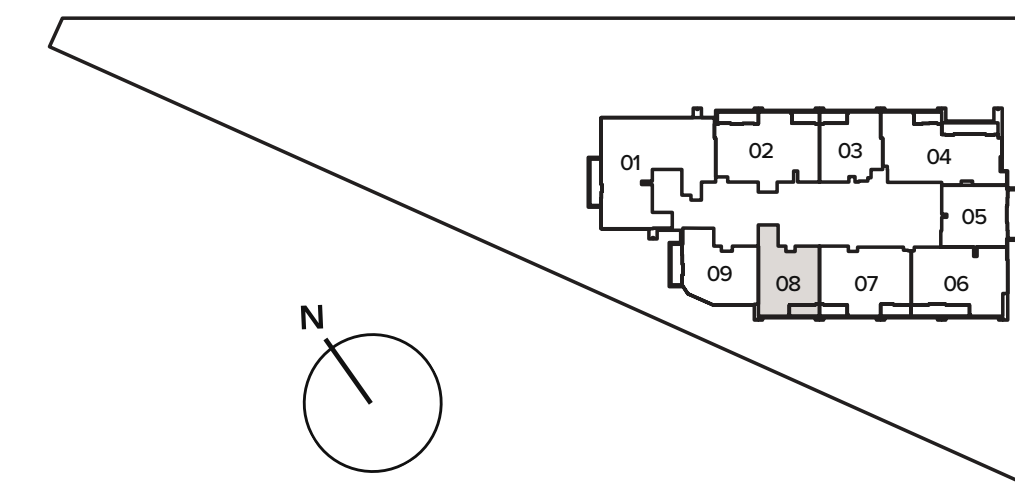

2 BEDROOM

TYPE A

Internal Living Area : 1337.31 Sq. Ft
 Outdoor Living Area : 152.63 Sq. Ft
 Total Living Area : 1489.94 Sq. Ft

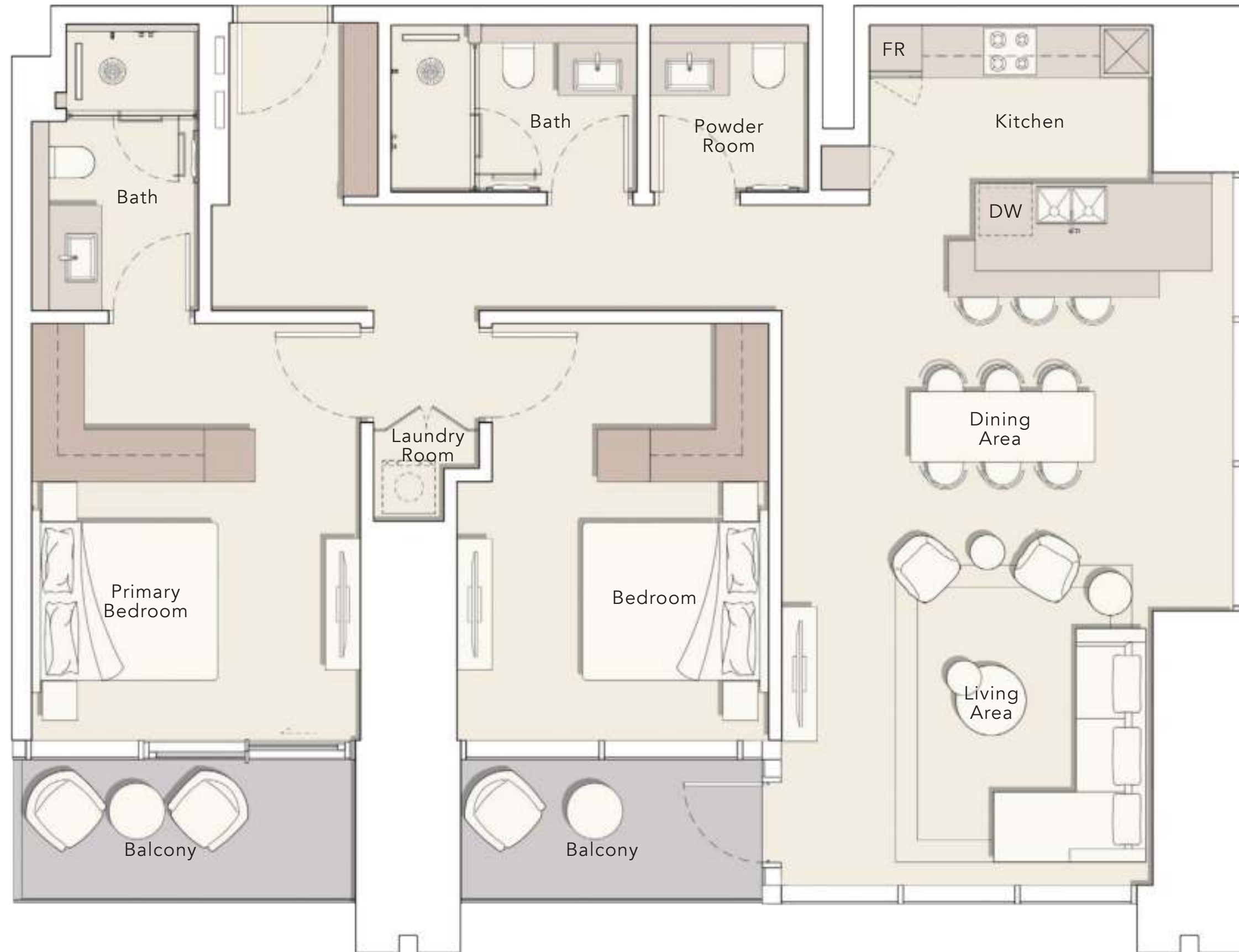

3rd FLOOR	7th FLOOR
304	704
4th FLOOR	8th - 16th FLOOR
404	806
5th FLOOR	18th - 36th FLOOR
504	1806
6th FLOOR	
604	

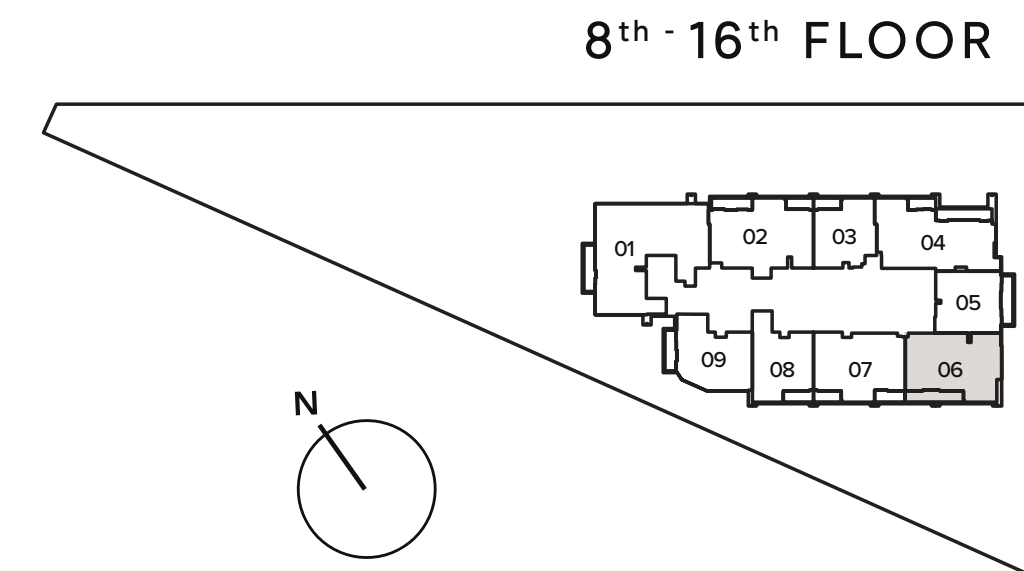

2 BED ROOM

TYPE B

Internal Living Area : 1295.22 Sq. Ft

Outdoor Living Area : 152.63 Sq. Ft

Total Living Area : 1447.85 Sq. Ft

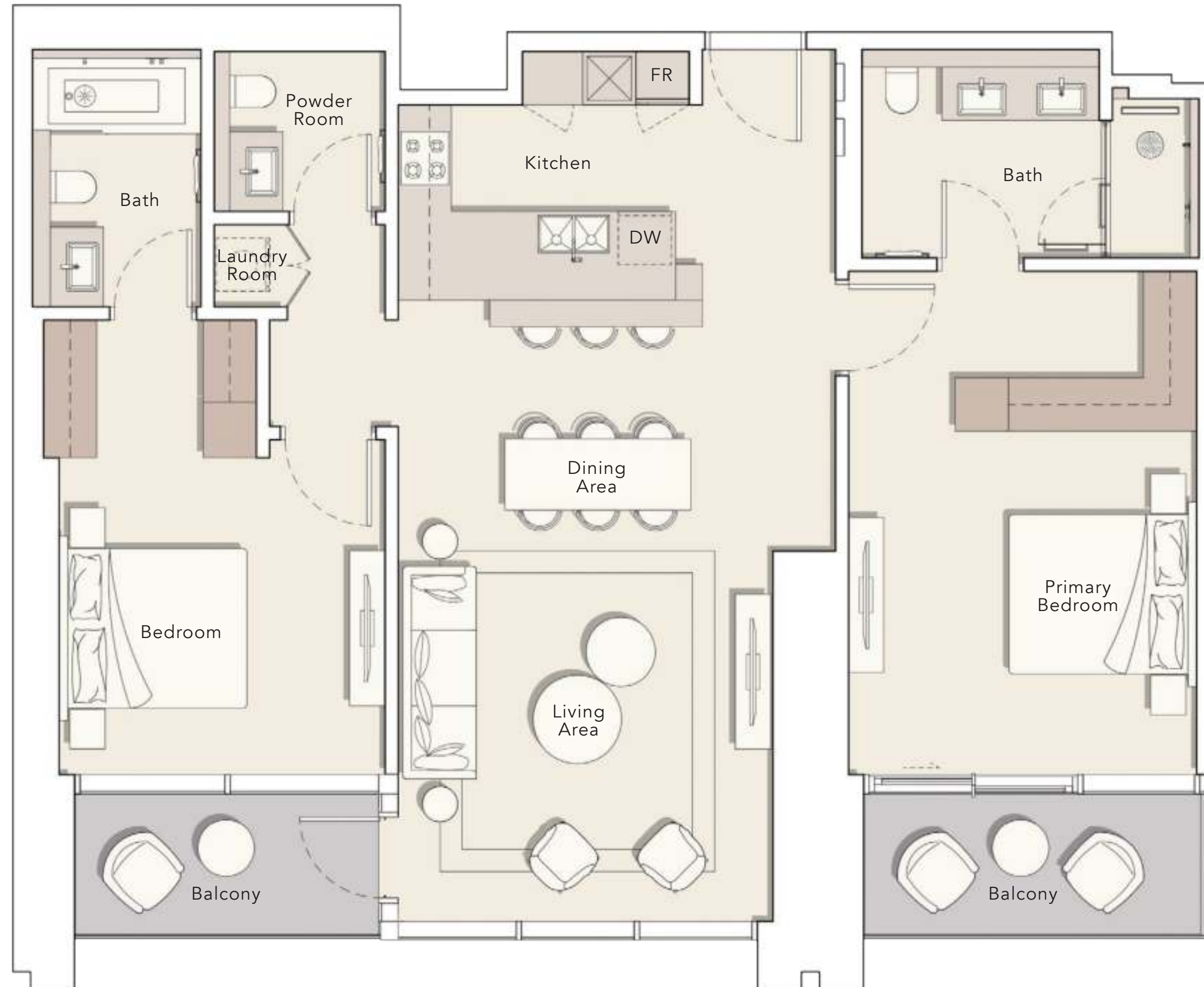

3rd FLOOR

305

7th FLOOR

705

4th FLOOR

405

8th - 16th FLOOR

807

5th FLOOR

505

6th FLOOR

605

8th - 16th FLOOR

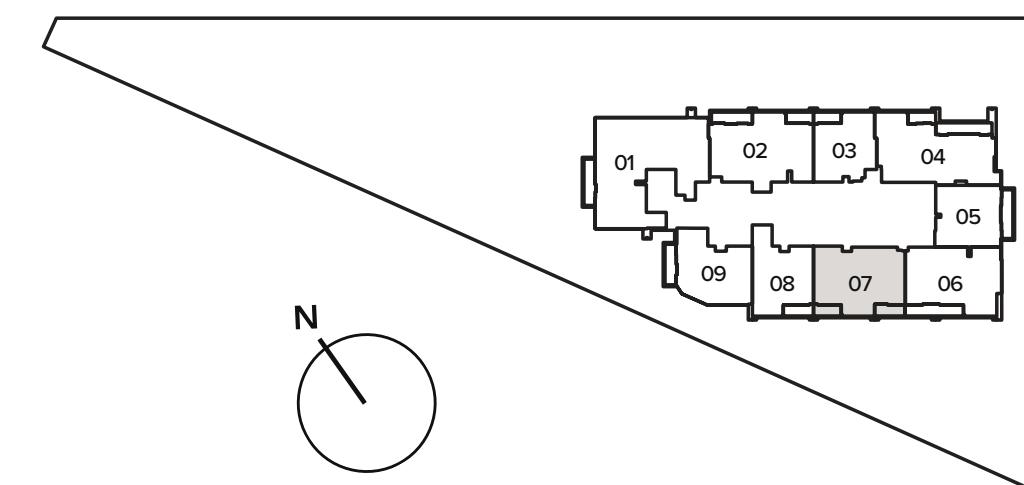

2 BEDROOM

TYPE C

Internal Living Area : 1328.48 Sq. Ft

Outdoor Living Area : 151.77 Sq. Ft

Total Living Area : 1480.25 Sq. Ft



18th - 36th FLOOR

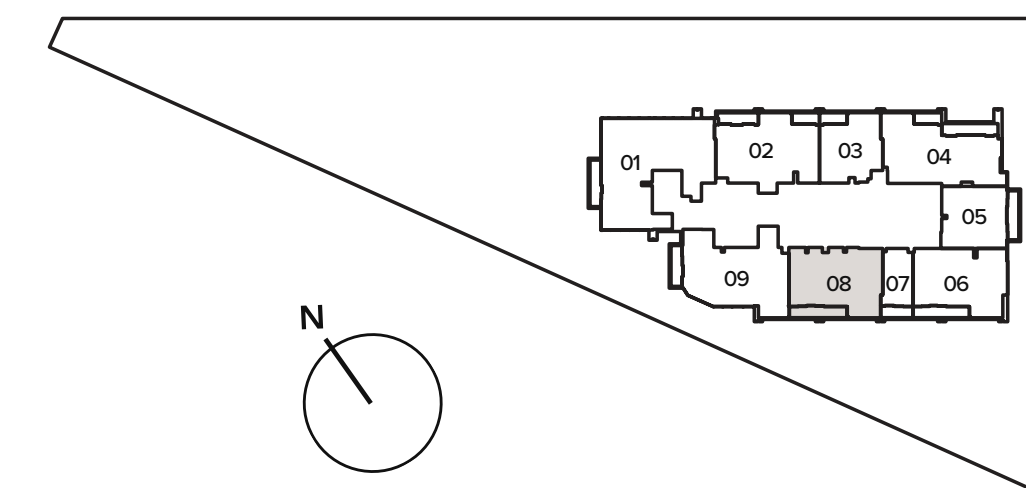

2 BEDROOM + S

TYPE A

Internal Living Area : 1573.04 Sq. Ft
 Outdoor Living Area : 222.92 Sq. Ft
 Total Living Area : 1795.96 Sq. Ft



- 3rd FLOOR**
302
- 4th FLOOR**
402
- 5th FLOOR**
502
- 6th FLOOR**
602
- 7th FLOOR**
702
- 8th - 16th FLOOR**
804
- 18th - 36th FLOOR**
1804

8th - 16th FLOOR

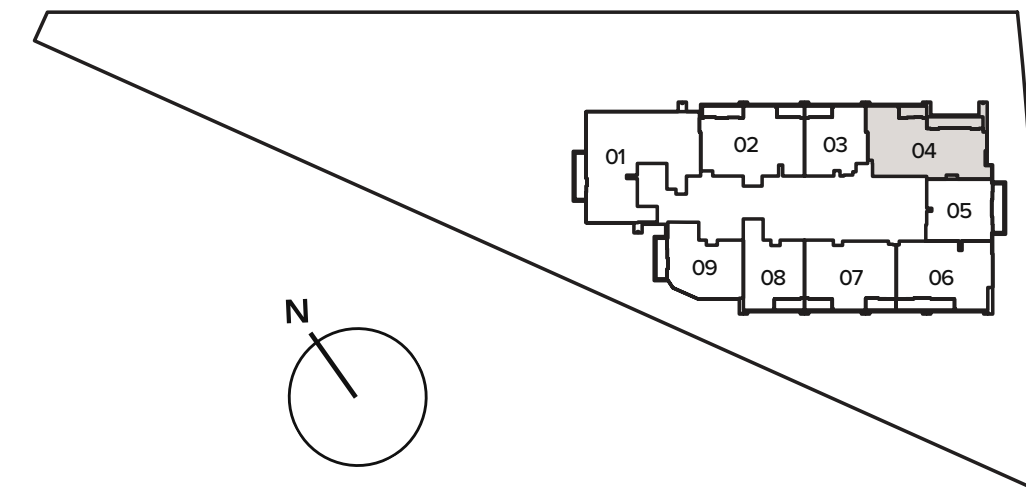

2 BEDROOM + S

TYPE B

Internal Living Area : 1509.53 Sq. Ft
Outdoor Living Area : 178.79 Sq. Ft
Total Living Area : 1688.32 Sq. Ft



8th - 16th FLOOR
802

18th - 36th FLOOR
1802

8th - 16th FLOOR

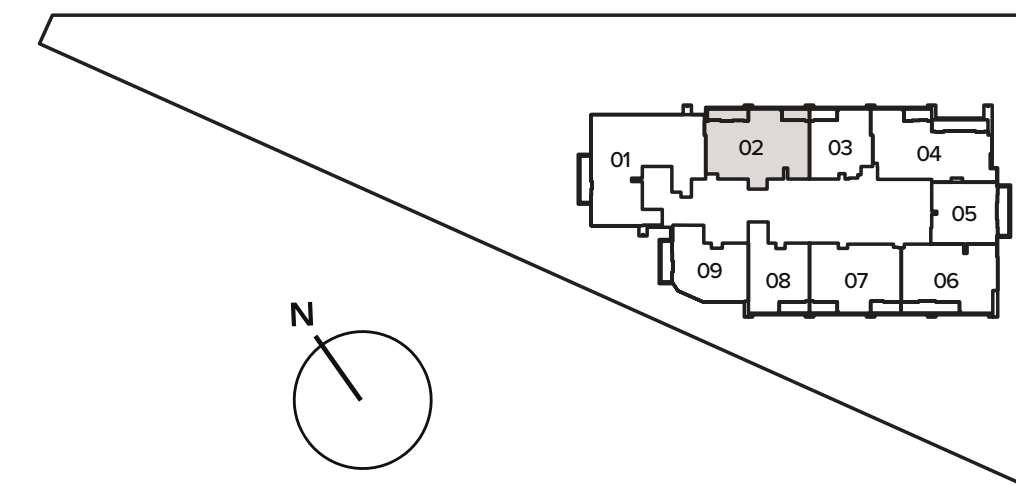

2 BEDROOM + S

TYPE C

Internal Living Area : 1678.20 Sq. Ft
Outdoor Living Area : 107.10 Sq. Ft
Total Living Area : 1785.30 Sq. Ft



18th - 36th FLOOR

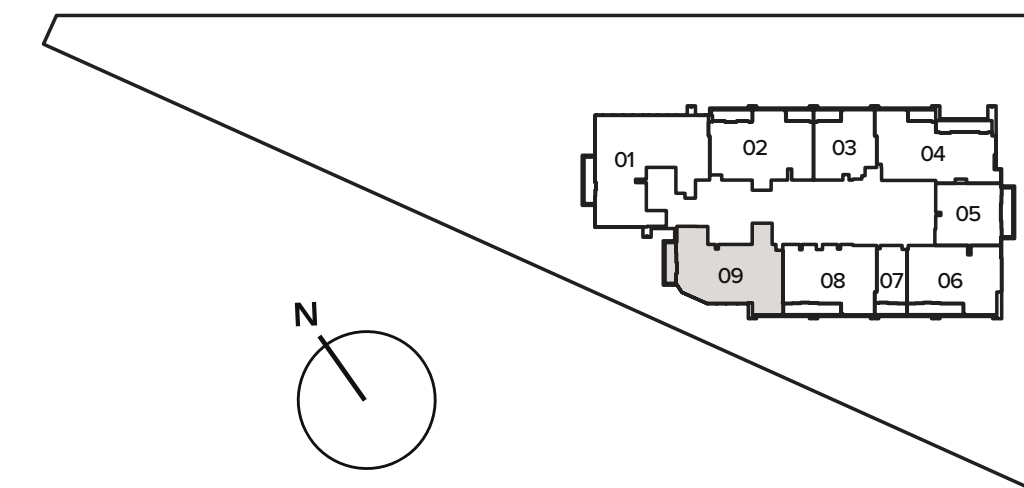

3 BEDROOM

TYPE A

Internal Living Area : 2276.24 Sq. Ft

Outdoor Living Area : 121.09 Sq. Ft

Total Living Area : 2397.34 Sq. Ft



8th - 16th FLOOR

801

18th - 36th FLOOR

1801

8th - 16th FLOOR

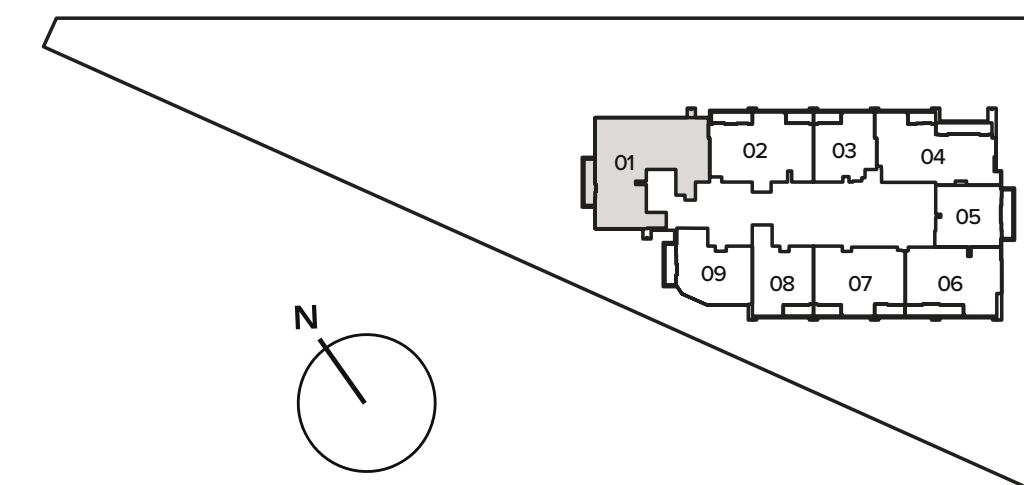

PREMIUM
APARTMENTS

3 BEDROOM DUPLEX

TYPE A

Internal Living Area : 3007.22 Sq. Ft

Outdoor Living Area : 707.30 Sq. Ft

Total Living Area : 3714.52 Sq. Ft

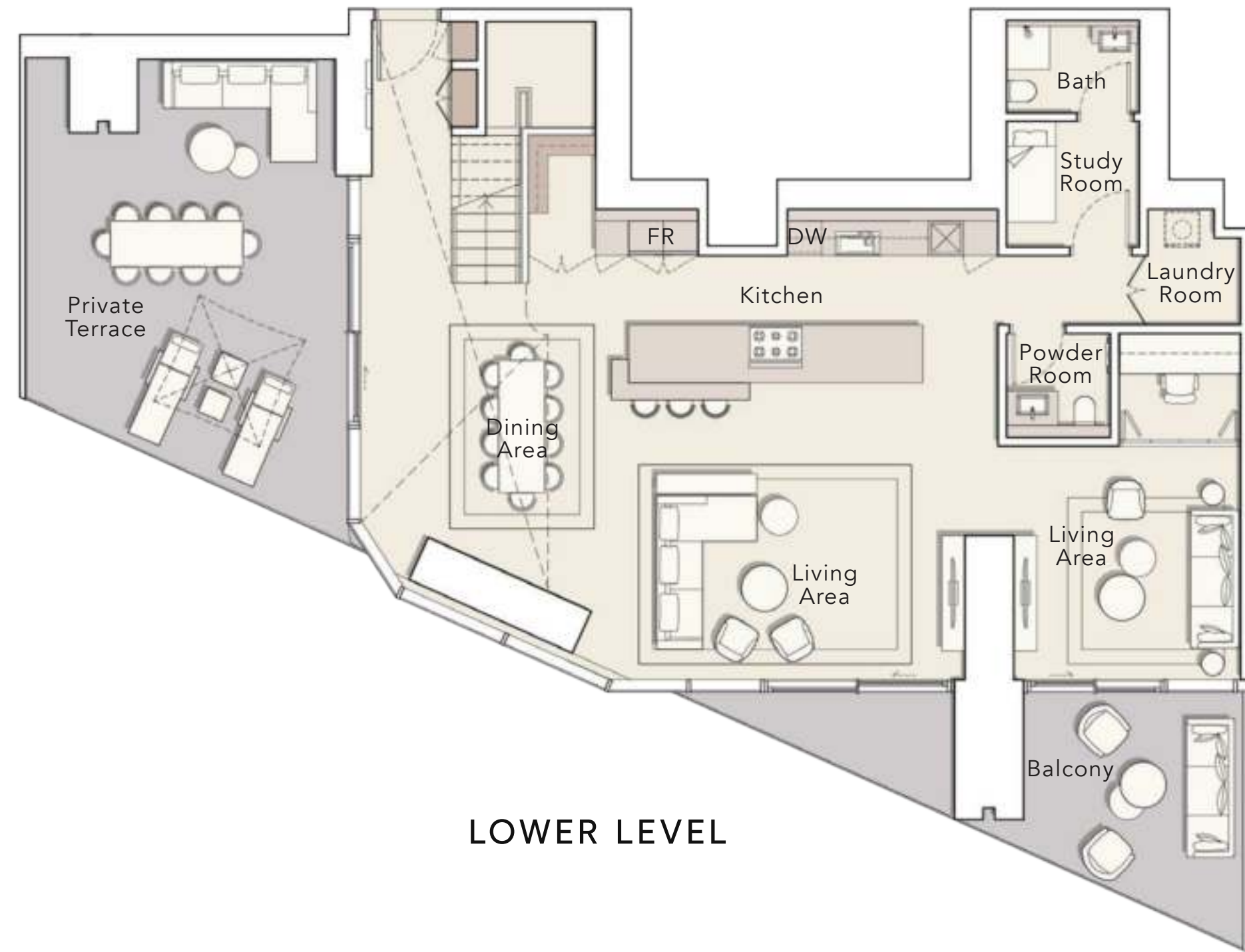

LOWER LEVEL

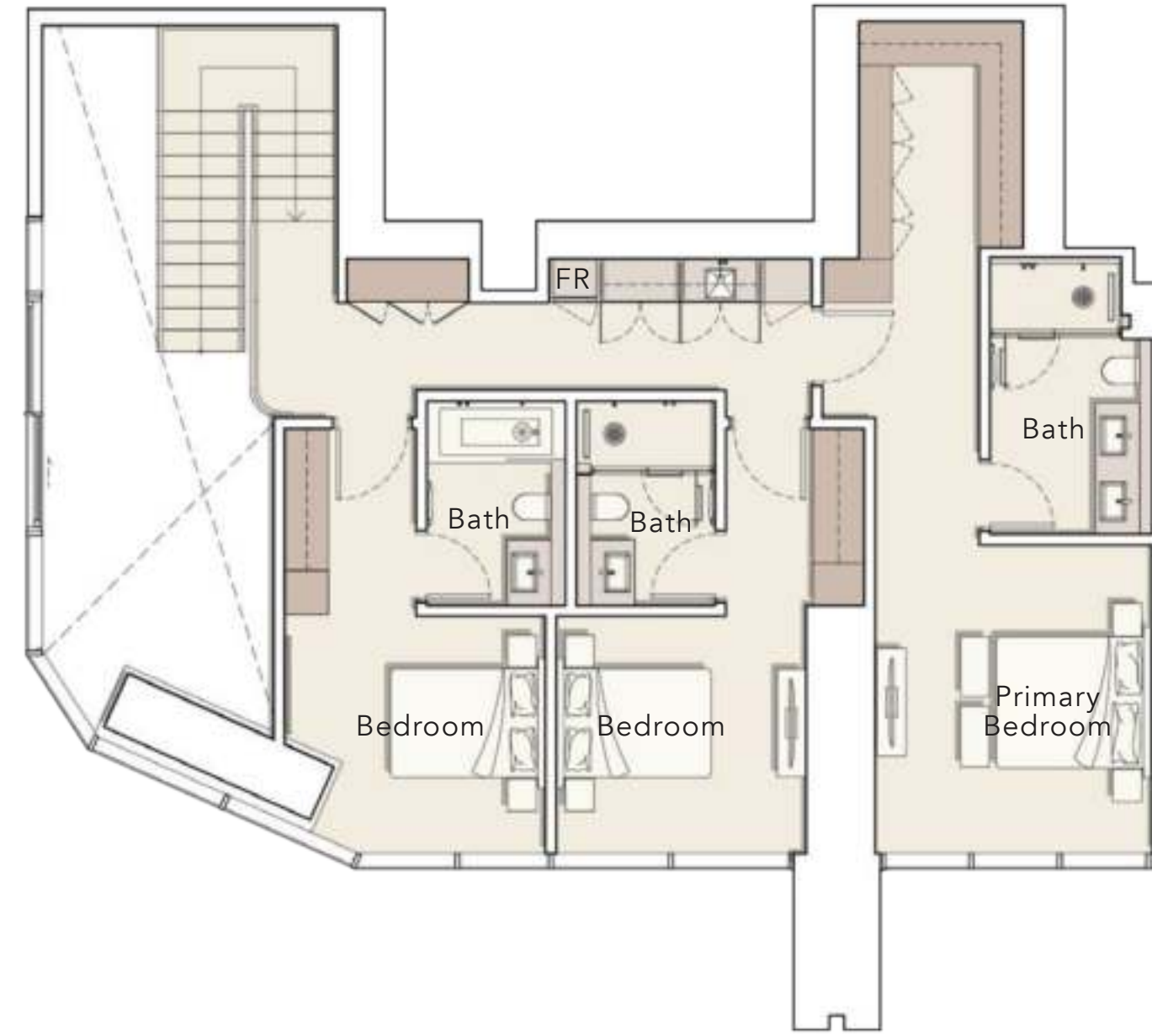

UPPER LEVEL

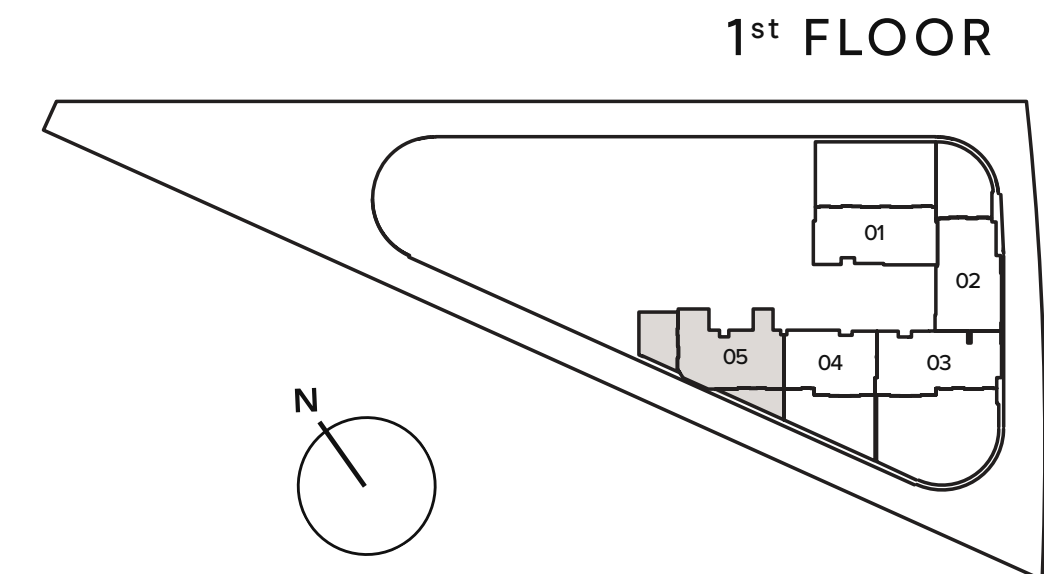

3 BEDROOM DUPLEX

TYPE B

Internal Living Area : 2468.49 Sq. Ft

Outdoor Living Area : 993.62 Sq. Ft

Total Living Area : 3462.10 Sq. Ft

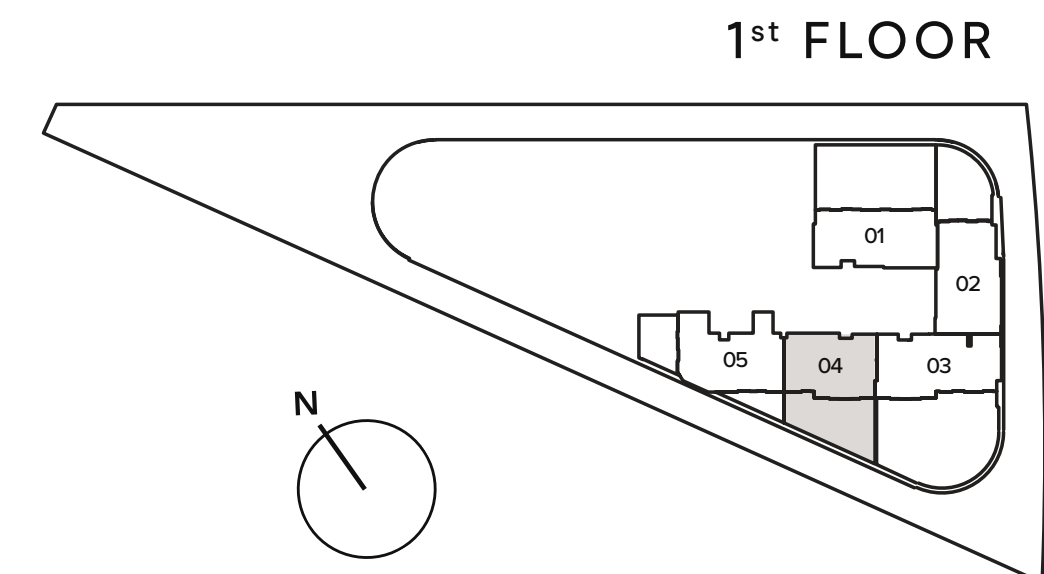
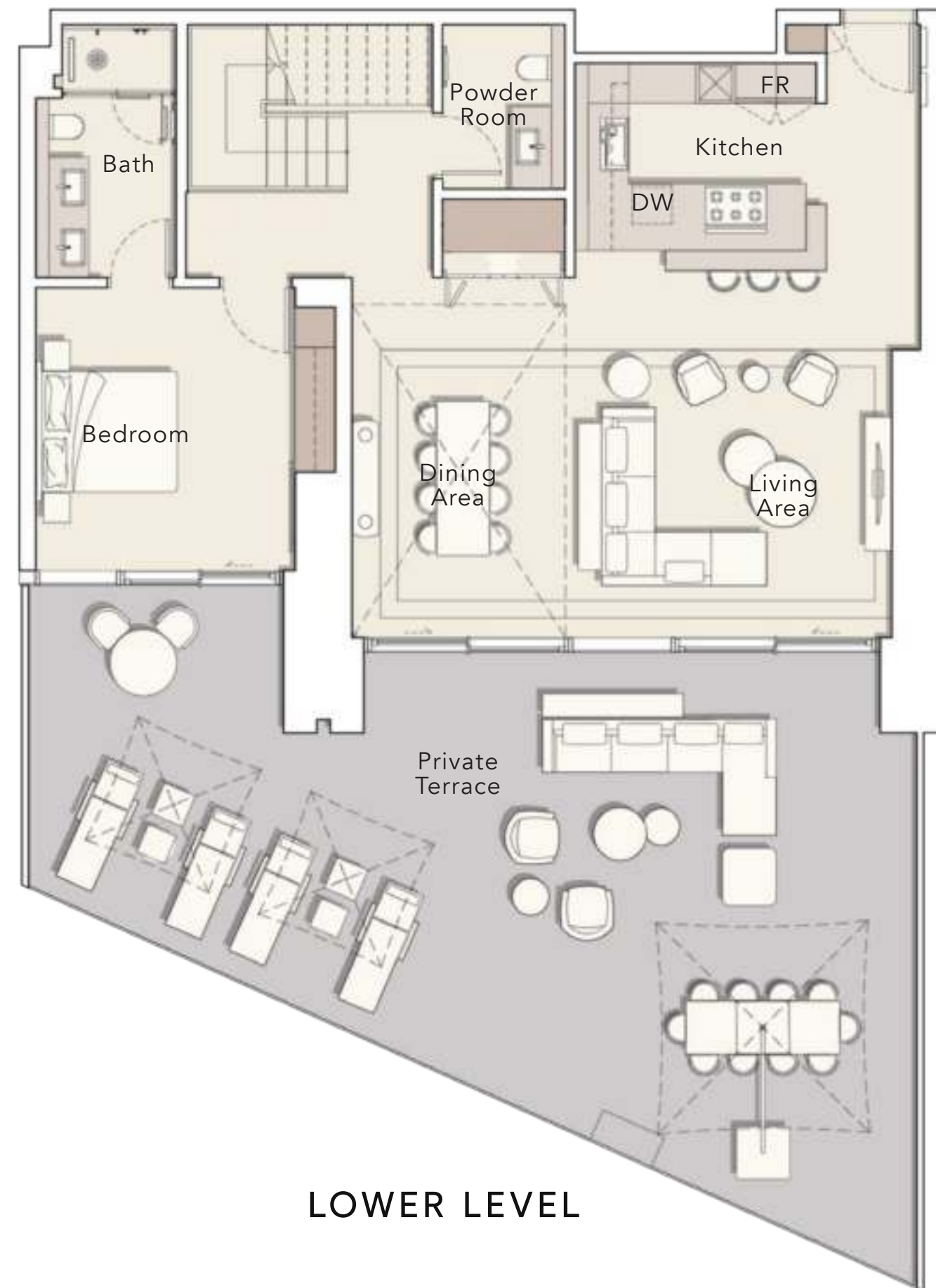

3 BEDROOM DUPLEX

TYPE C

Internal Living Area : 3125.73 Sq. Ft
Outdoor Living Area : 842.92 Sq. Ft
Total Living Area : 3968.65 Sq. Ft

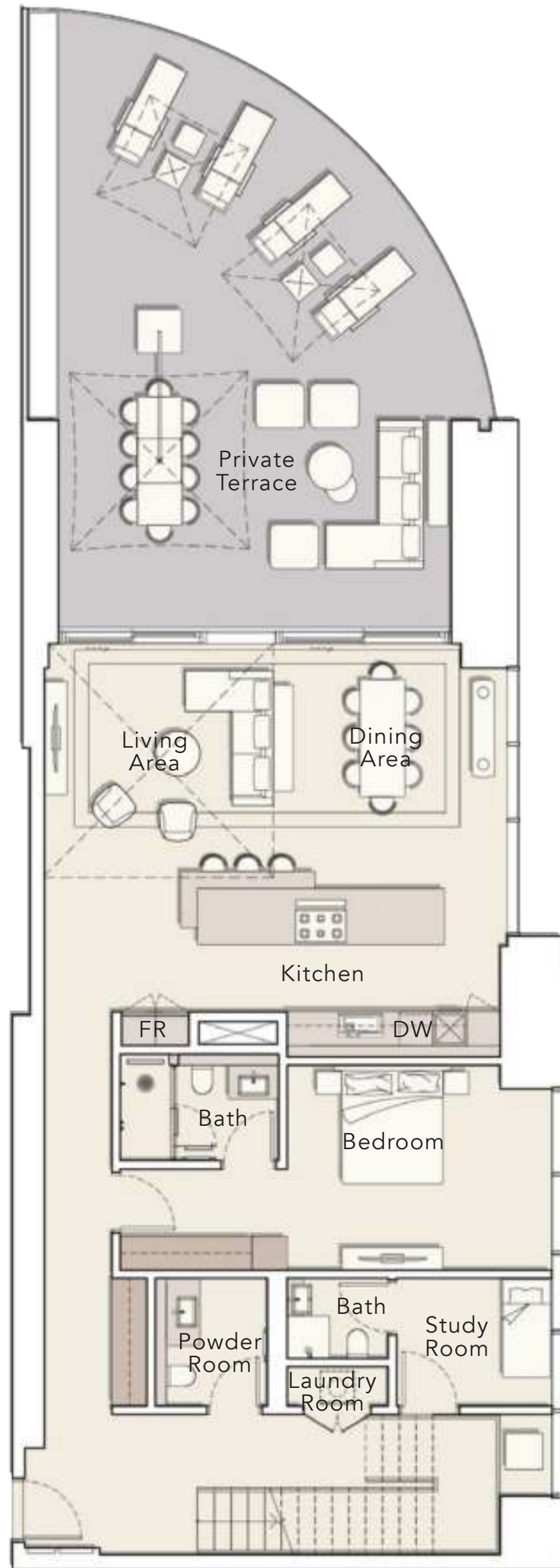

LOWER LEVEL



UPPER LEVEL

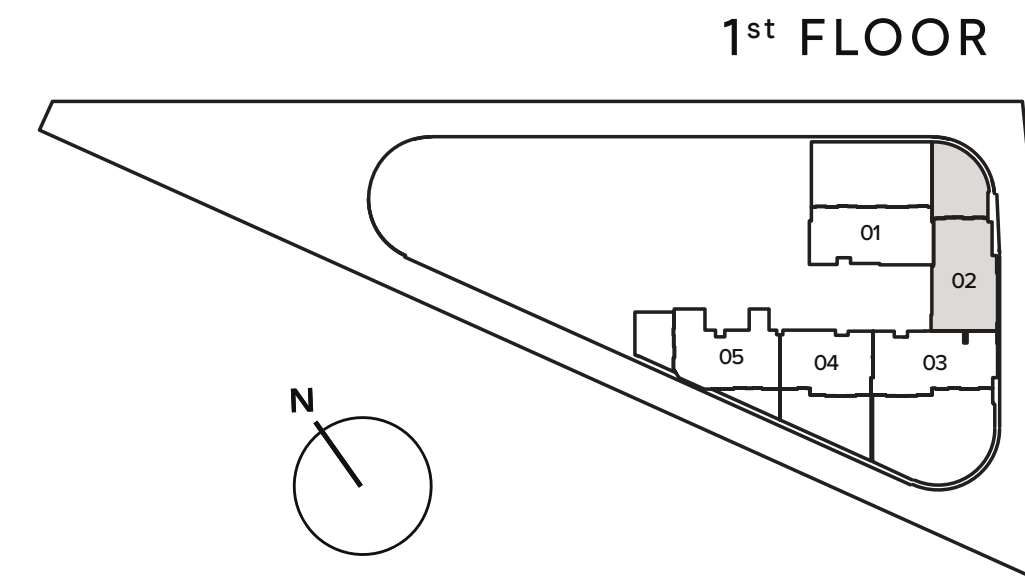

1st FLOOR

4 BEDROOM DUPLEX

TYPE A

Internal Living Area : 3128.96 Sq. Ft

Outdoor Living Area : 1842.89 Sq. Ft

Total Living Area : 4971.85 Sq. Ft

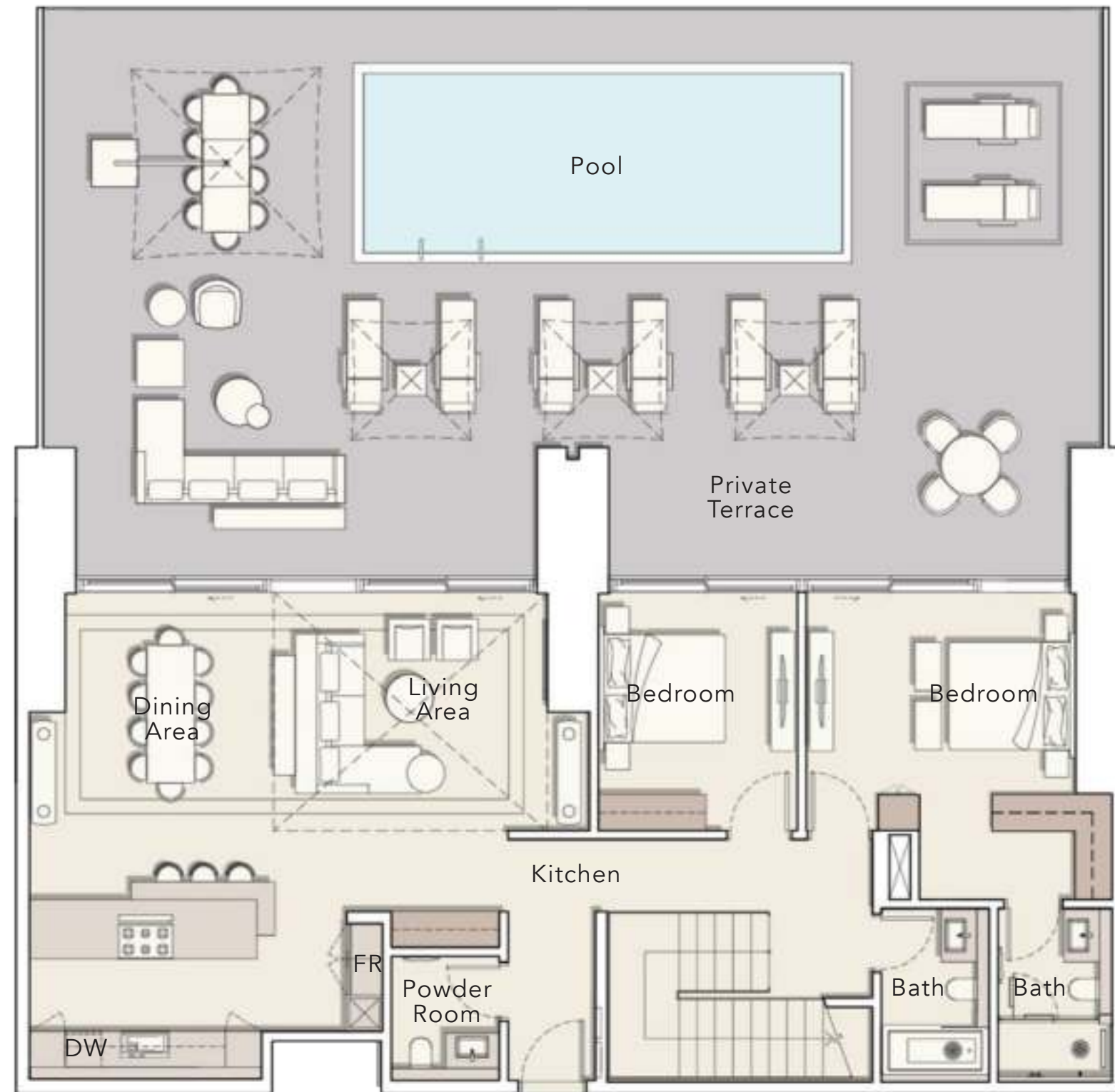

LOWER LEVEL



UPPER LEVEL

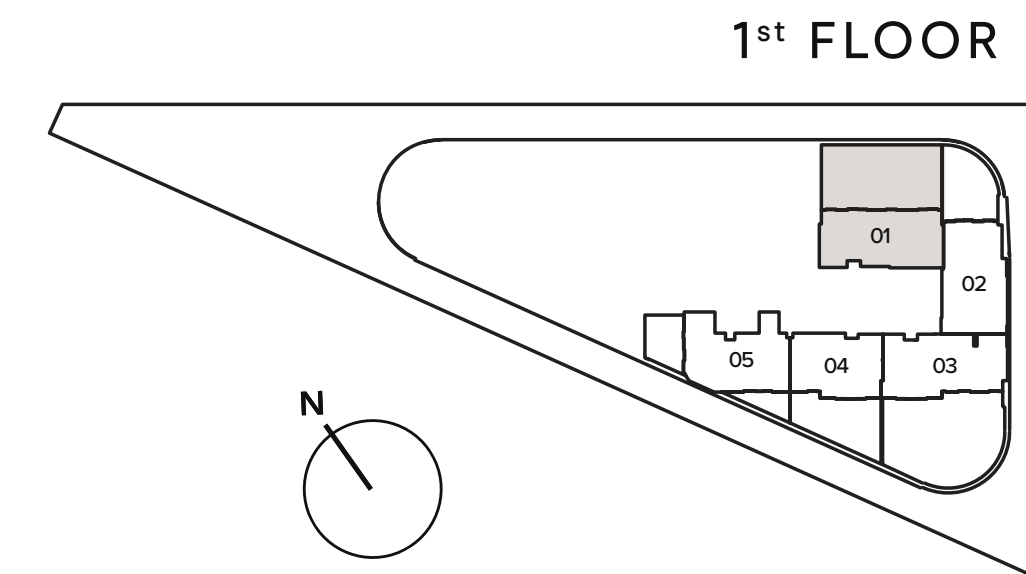

1st FLOOR

4 BEDROOM DUPLEX

TYPE B

Internal Living Area : 3246.50 Sq. Ft

Outdoor Living Area : 2329.74 Sq. Ft

Total Living Area : 5576.24 Sq. Ft

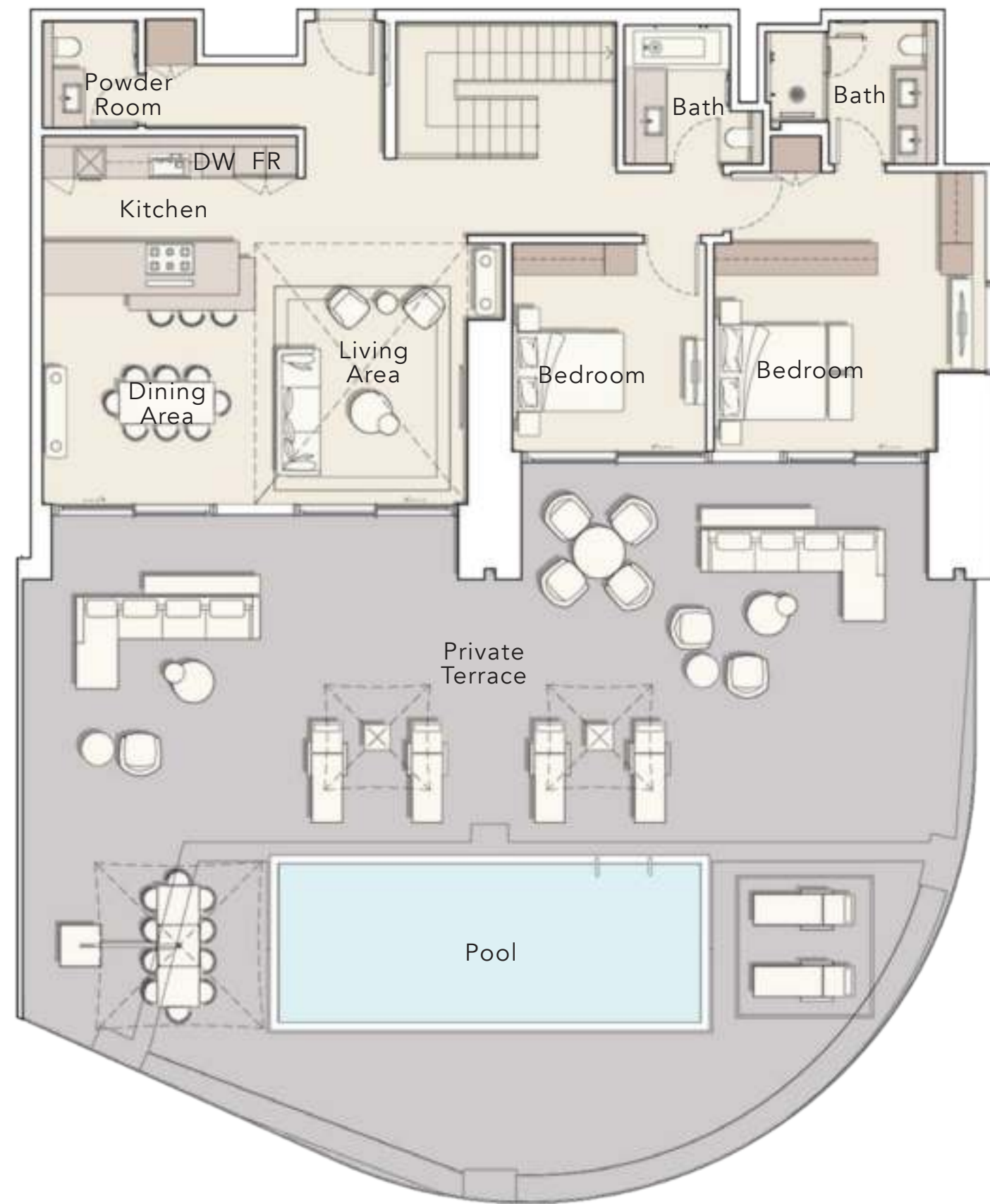

LOWER LEVEL



UPPER LEVEL

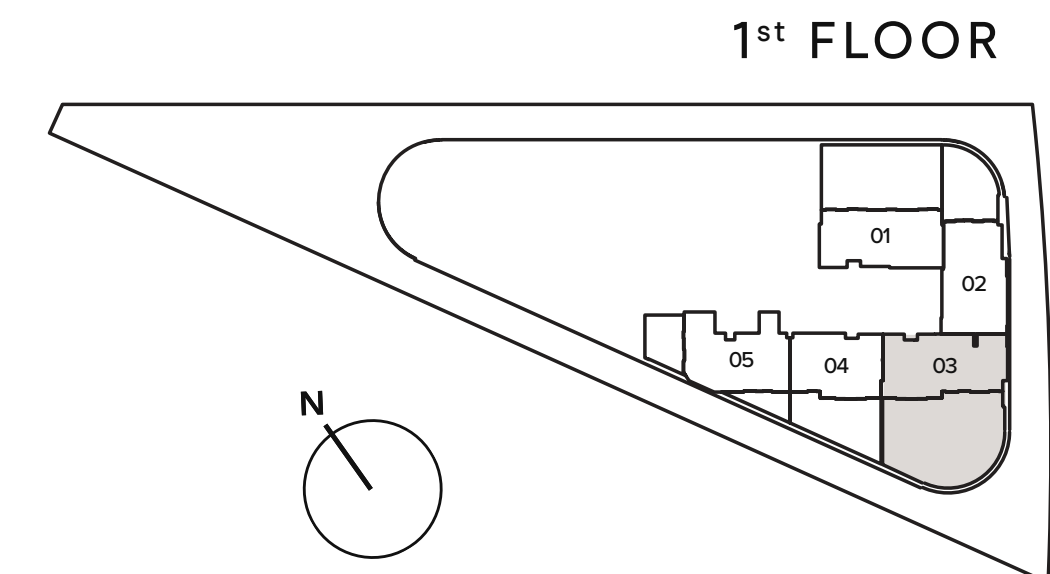

1st FLOOR

PENTHOUSE

TYPE A

Internal Living Area : **3398.92 Sq. Ft**

Outdoor Living Area : **2448.57 Sq. Ft**

Total Living Area : **5847.49 Sq. Ft**

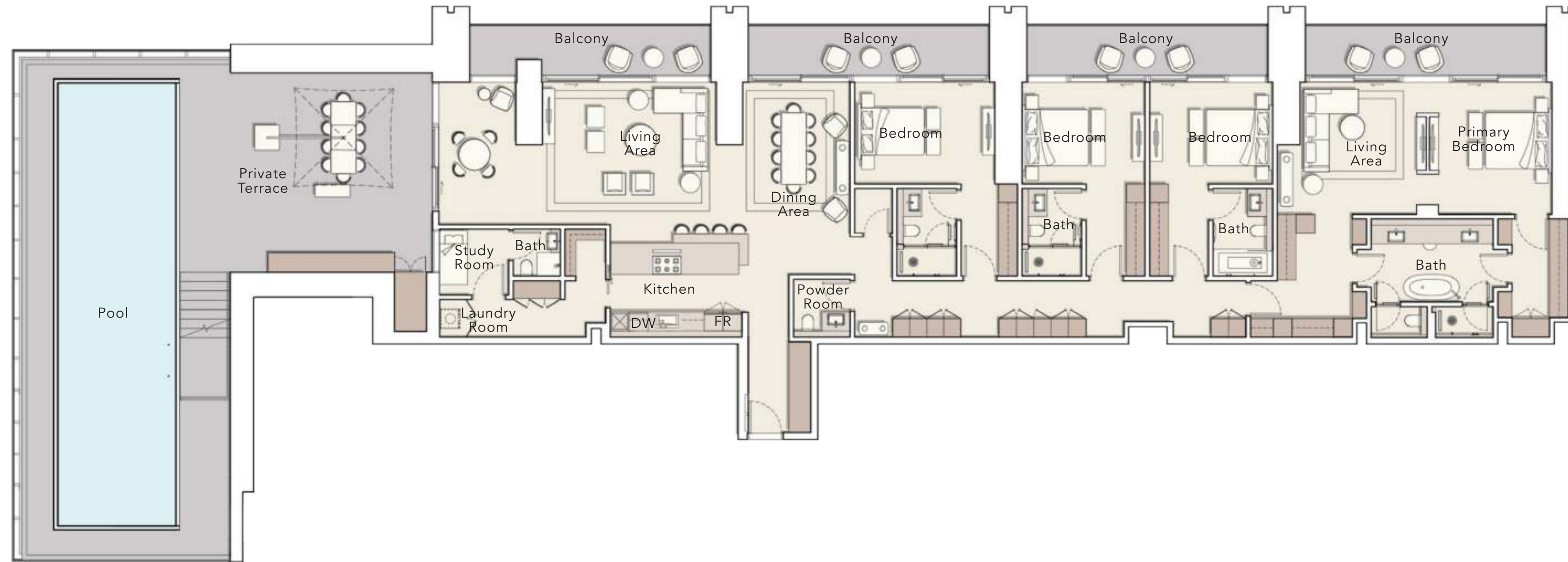

37th FLOOR

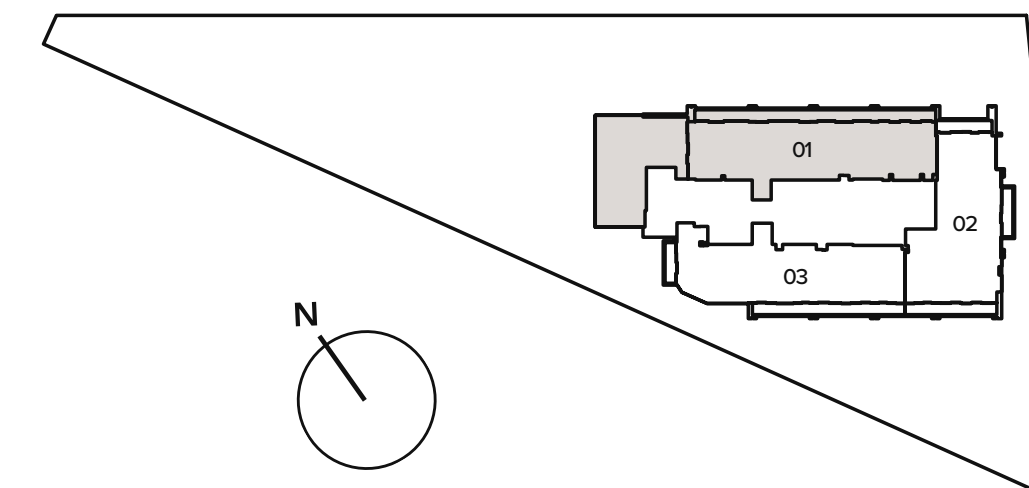

PENTHOUSE

TYPE B

Internal Living Area : 3221.42 Sq. Ft

Outdoor Living Area : 513.22 Sq. Ft

Total Living Area : 3734.65 Sq. Ft

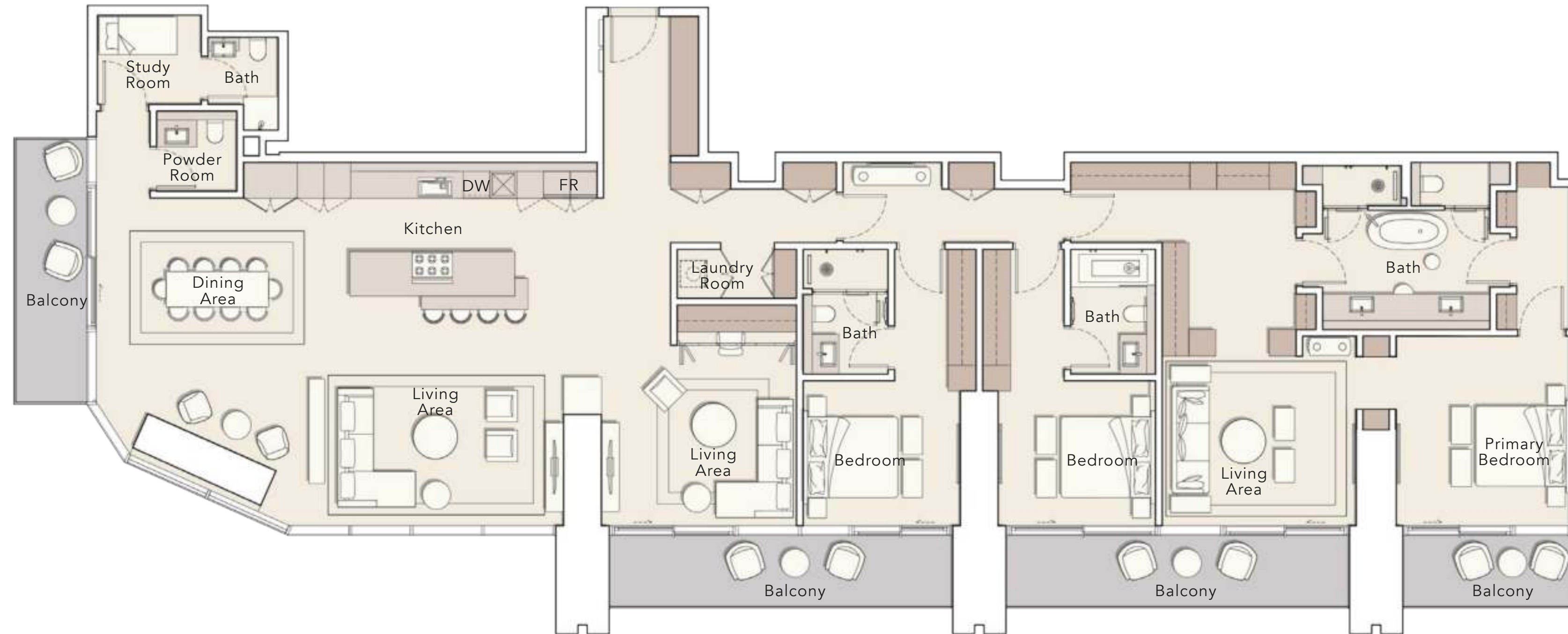

37th FLOOR

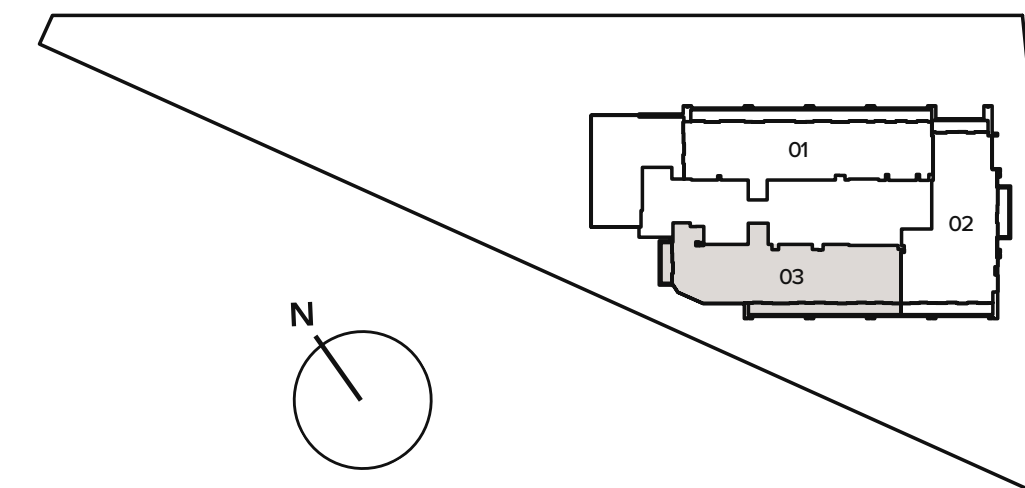

PENTHOUSE

TYPE C

Internal Living Area : 2980.96 Sq. Ft

Outdoor Living Area : 521.83 Sq. Ft

Total Living Area : 3502.79 Sq. Ft

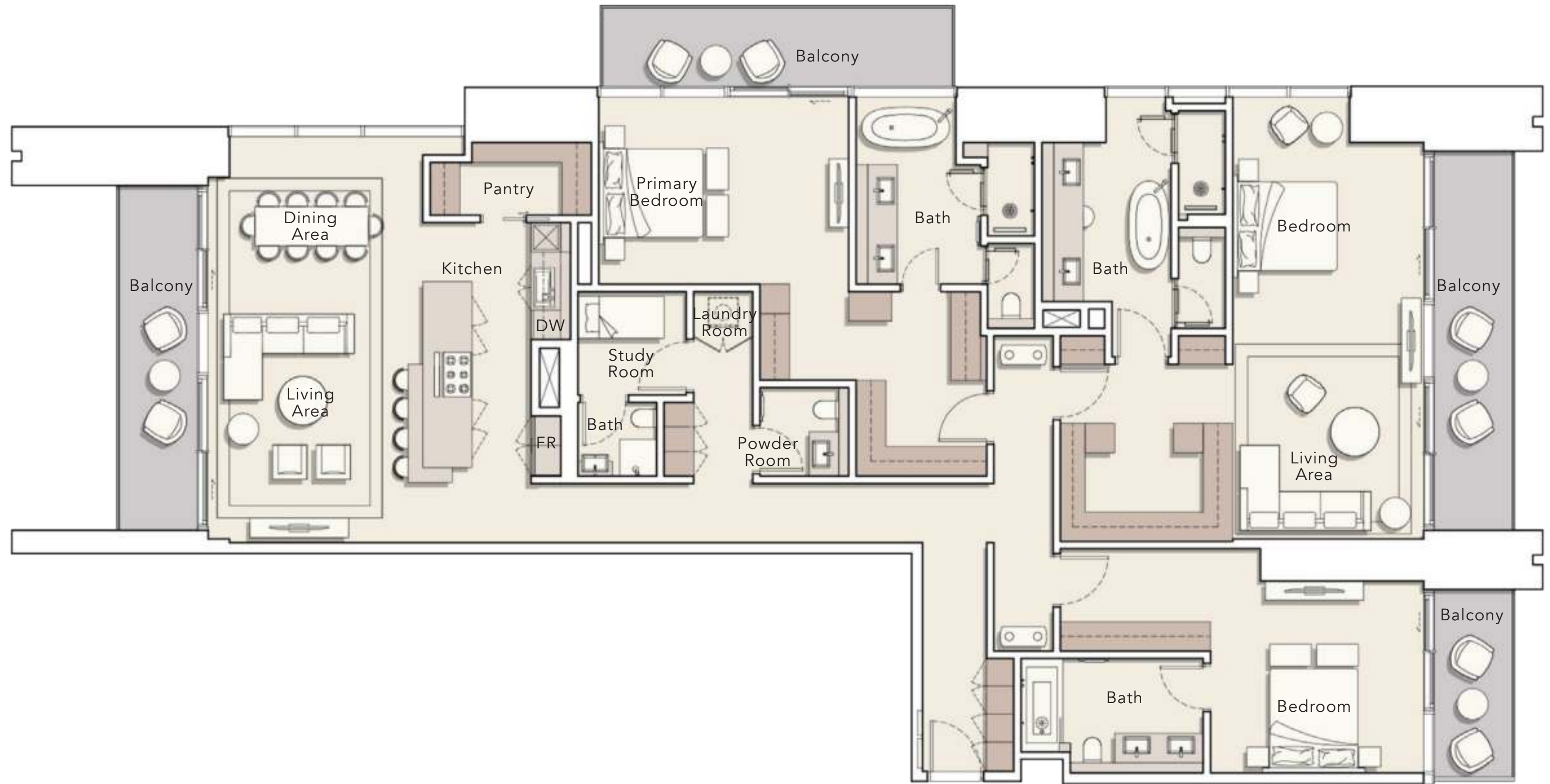

37th FLOOR

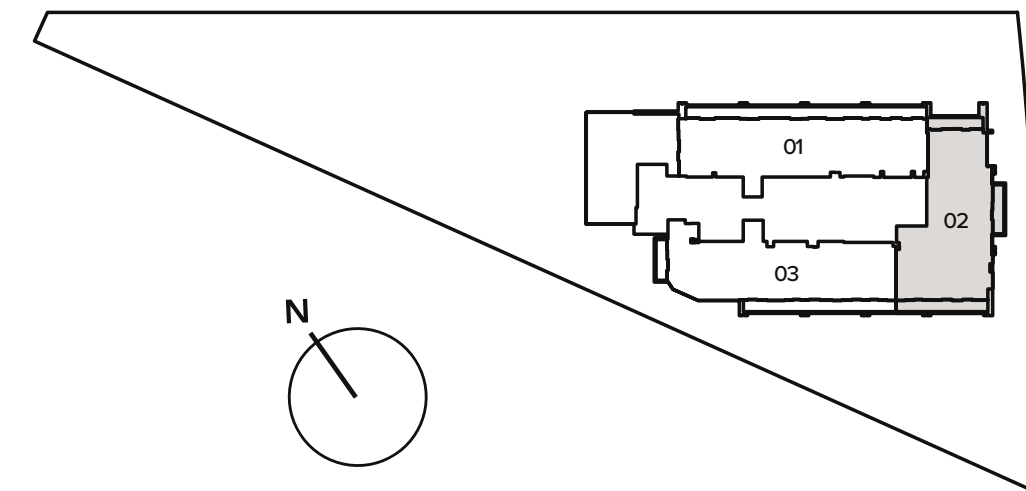

PAYMENT PLAN

20%

At the time of booking

10%

30 days after the reservation date

10%

90 days after the reservation date

5%

150 days after the reservation date

5%

240 days after the reservation date

5%

On completion of 30% construction of the project

5%

On completion of 40% construction of the project

5%

On completion of 50% construction of the project

5%

On completion of 60% construction of the project

30%

On completion